



LARGE VOLUME DEEP FRYER – AUTO-LIFT – MANUAL CONTROLS – FILTER SYSTEM

Model ALF-F



ALF-F model with LTS landing table.

This large electric auto-lift fryer is designed for simple operation, long life, and medium to high volume. The manual controls are easy to use and the lower initial cost will get you cooking fast. The BKI® ALF-F fryer cooks up to 14 lb (6.4 kg) of product in one cycle and holds 48 lb (21.8 kg) of oil.

Open-vat fryers are perfect for producing extra-crispy exteriors and tender interiors on a variety of fried foods. The auto-lift basket ensures that food is removed from the oil at the precise moment it is completely cooked. It also lifts food out of the vat at the precise moment it is fully cooked to avoid overcooking. Combine this fryer with a BKI hot case and your food will be hot and crispy for hours!

The amazing efficiency and fast recovery times of the ALF series electric fryers are realized by the placement of the heating elements completely inside the vat with oil flowing freely around them.

The built-in filtration system keeps oil fresh and extends its usable life. This saves you money over the life of the fryer and keeps your food tasting consistent every time. A cold zone in the vat collects breading fall-off, keeping oil fresh and clean. With the push of a button and the twist of a handle, filtering oil is easy and safe. The patented quick-disconnect allows for easy removal of the filtering vat.

FEATURES AT A GLANCE

- 14 lb (6.4 kg) product, 48 lb (21.8 kg) oil capacity
- Auto-lift basket for precise cooking
- 3" casters for easy mobility
- Stainless steel construction
- Manual controls
- Digital timer
- Built-in filtration system
- Assembled in USA

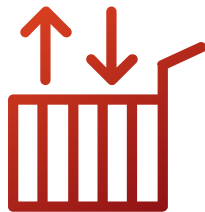

AUTO-LIFT BASKET

The auto-lift basket feature pulls the product from oil when cook cycle is complete.



ELECTRIC OPERATION

Energy efficiency and easy installation are a perfect pairing for your food service operation.

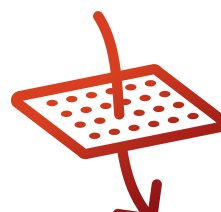

BUILT-IN FILTRATION

The filtration system ensures consistent-tasting food and longer oil life.



LARGE VOLUME DEEP FRYER – AUTO-LIFT – MANUAL CONTROLS – FILTER SYSTEM

Model ALF-F

EQUIPMENT DIMENSIONS

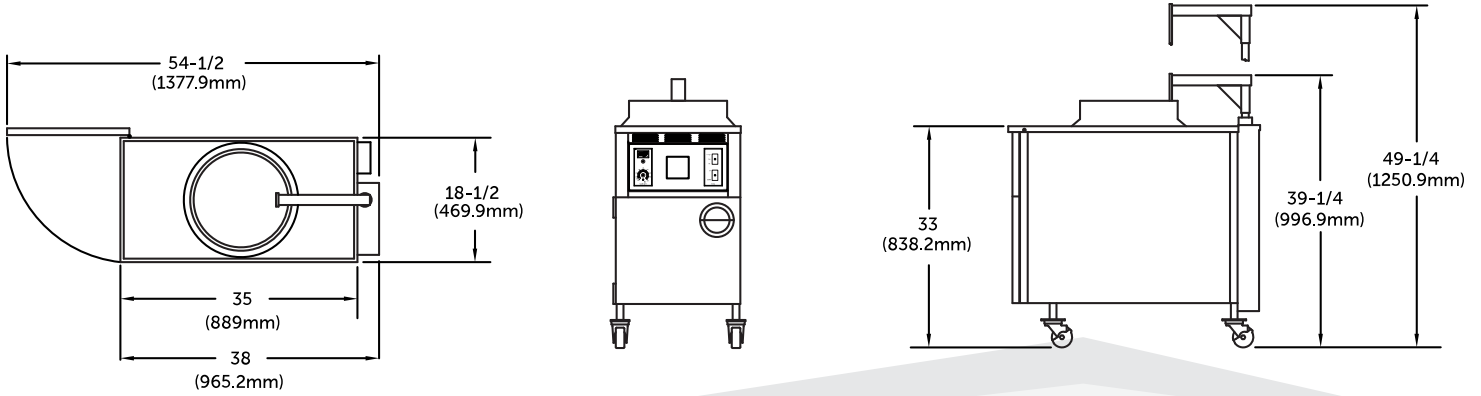

MECHANICAL SPECIFICATIONS

Dimension	Uncrated	Crated
Height	39.25" (997 mm)	58" (1476 mm)
Width	18.5" (470 mm)	27" (687 mm)
Depth	38" (967 mm)	42" (1069 mm)
Floor Space	6.4 sq ft (.59 sq m)	7.9 sq ft (.73 sq m)
Weight	265 lb (127 kg)	280 lb (127 kg)

ELECTRICAL OPTIONS

Volts	Amps	Breaker	kW	Wires	Phase
208	65/38	80/45	13.5	2/3	1/3
220	57/33	70/40	13.5	2/3	1/3
240	57/33	70/40	13.5	2/3	1/3
208/240	38/33	50/45	13.5	3	3

INCLUDED ACCESSORIES

- 1 White pot scrubber brush
- 1 Long black brush
- 1 Short black brush
- 1 L-tipped brush
- 1 White drain brush
- 1 Basket to be used with lift handle
- 1 Pair 13" insulated mitts
- 5 Filter Paper



Visit bkideas.com to view all accessories available for this model.

4.4.2019

bkideas.com

© BKI LI0283C/08-06

Specifications are subject to change without notice.

BKI Worldwide, Inc.
 2812 Grandview Drive
 Simpsonville, SC 29680
 Telephone: (864) 963-3471
 Toll Free: (800) 927-6887

Dimensions nominal.
 Shipping Class: #85
 FOB Simpsonville, SC