



**X-LARGE VOLUME DEEP FRYER – PRESSURE –
MANUAL CONTROLS – FILTER SYSTEM – ELECTRIC OPERATION**

Model FKM-F



The workhorse of pressure fryers, this extra-large electric pressure fryer is designed for simple operation, long life, and high volume. The manual controls are easy to use and the lower initial cost will get you cooking fast. The BKI® FKM-F fryer cooks up to 24 lb (10.8 kg) of product with our optional grande basket in one cycle and holds 75 lb (34 kg) of oil.

The results from pressure frying are delicious! As pressure builds up in the vat, moisture in the protein is trapped, leaving you with perfectly tender and moist meat while retaining a crispy exterior. Food coming out of the pressure fryer has a longer holding "life" too, which is perfect for grocery deli grab-n-go displays. Combine this fryer with a BKI warmer and your food will be hot and crispy for hours!

The amazing efficiency and fast recovery times of the FKM series electric fryers are realized by the placement of the heating elements completely inside the vat with oil flowing freely around them.

The semi-automatic filtration system keeps oil fresh and extends its usable life. This saves you money over the life of the fryer and keeps your food tasting consistent every time. A cold zone in the vat collects breading fall-off, keeping oil fresh and clean. With the push of a button and the twist of a handle, filtering oil is easy and safe. The patented quick-disconnect allows for easy removal of the filtering vat.

FEATURES AT A GLANCE

- 24 lb (10.8 kg) product with optional grande basket, 75 lb (34 kg) oil capacity
- Utilizes controlled low pressure
- Pressure-regulated lid interlock system
- 5" casters for easy mobility
- Stainless steel construction
- Manual controls
- Digital timer
- Built-in filtration system
- Assembled in USA



PRESSURE COOKING

Pressure cooking results in moist and tender meat and longer holding life.



ELECTRIC OPERATION

Energy efficiency and easy installation are a perfect pairing for your food service operation.

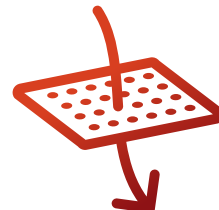

SEMI-AUTO FILTRATION

Semi-automatic filtration system filters after every batch without operator input.

www.bkideas.com

42 Allen Martin Drive, Essex Junction, VT 05452 • Phone: (802) 658-6600 • Fax: (802) 864-0183

BK1272 Rev D (4/25)

EQUIPMENT DIMENSIONS

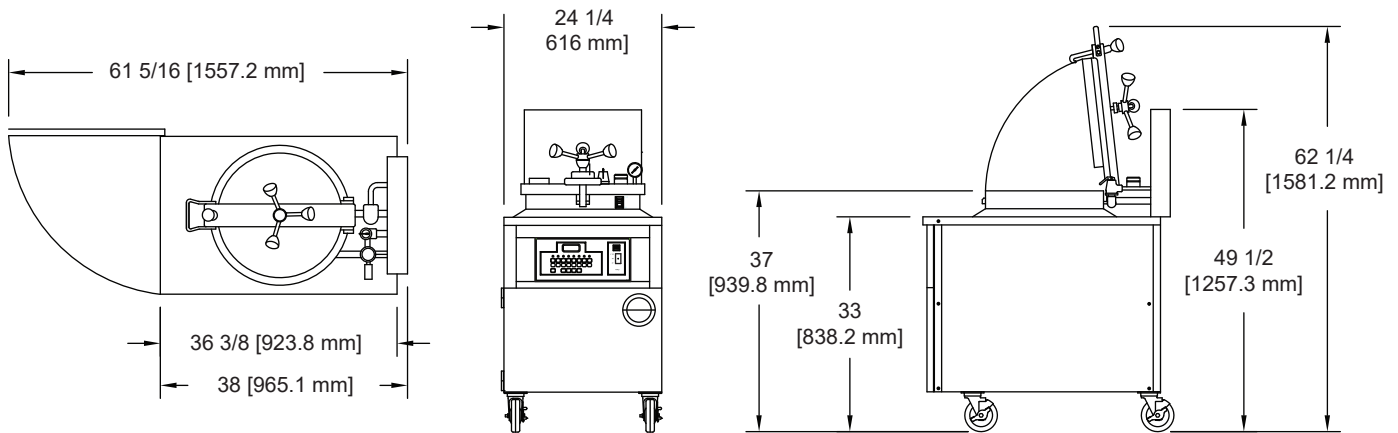

MECHANICAL SPECIFICATIONS

Dimensions	Uncrated	Crated
Height	49 1/2" (1257.3 mm)	60" (1524 mm)
Width	24 1/4" (616 mm)	31" (787 mm)
Depth	38" (965.1 mm)	45" (1143 mm)
Floor space	6.4 sq ft (.59 sq m)	7.9 sq ft (.73 sq m)
Weight	385 lb (174.6 kg)	405 lb (184 kg)

ELECTRICAL OPTIONS

Volts	Amps	Breaker	kW	Wires	Phase
208	47.3	60	17	3	3
240	41	50	17	3	3
220/380	21.7	30	14.3	4	3
230/400	22.8	30	15.6	4	3
240/415	23.7	30	17	4	3
480	20.5	30	17	4	3

OPERATING PRESSURE

Operating PSI	12 PSI
Safety Release PSI	15 PSI

INCLUDED ACCESSORIES

- 1 White pot scrubber brush
- 1 Long black brush
- 1 Short black brush
- 1 L-tipped brush
- 1 White drain brush
- 1 Bail handle basket
- 1 Pair 13" insulated mitts
- 5 Filter Paper



Visit www.bkideas.com to view all accessories available with this model.