



**X-LARGE VOLUME DEEP FRYER – PRESSURE –
TOUCHPAD CONTROLS – FILTER SYSTEM – GAS OPERATION**

Model FK^G-FC



The workhorse of pressure fryers, this extra-large natural-gasoperated pressure fryer is designed for simple operation, long life, and high volume. The touchpad controls are easy to use and program for true one-touch cooking. The BKI® FK^G-FC fryer cooks up to 18 lb (8.2 kg) of product in one cycle and holds 75 lb (34 kg) of oil.

The results from pressure frying are delicious! As pressure builds up in the vat, moisture in the protein is trapped, leaving you with perfectly tender and moist meat while retaining a crispy exterior. Food coming out of the pressure fryer has a longer holding "life" too, which is perfect for grocery deli grab-n-go displays. Combine this fryer with a BKI warmer and your food will be hot and crispy for hours!

The amazing efficiency and fast recovery times of the FK^G-FC series gas fryers are realized by the placement of the heating elements completely inside the vat with oil flowing freely around them.

The semi-automatic filtration system keeps oil fresh and extends its usable life. This saves you money over the life of the fryer and keeps your food tasting consistent every time. A built-in cold zone in the vat collects breading fall-off, keeping oil fresh and clean. With the push of a button and the twist of a handle, filtering oil is easy and safe. The patented quick-disconnect allows for easy removal of the filtering vat.

FEATURES AT A GLANCE

- 18 lb (8.2 kg) product, 75 lb (34 kg) oil capacity
- Utilizes controlled low pressure
- Pressure-regulated lid interlock system
- 5" casters for easy mobility
- Gas operation
- Stainless steel construction
- Microprocessor controlled for enhanced cooking capabilities
- Automatic, quick-disconnect filter system
- 100% hand built in the U.S.A.



PRESSURE COOKING

Pressure cooking results in moist and tender meat and longer holding life.



GAS OPERATION

Natural/LP gas is powerful and efficient with incredible recuperation times.



TOUCHPAD CONTROLS

Touchpad controls are easy to use and ensure menu items are perfectly cooked.

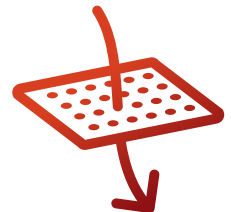

SEMI-AUTO FILTRATION

Automatic filtration system filters after every batch without operator input.

EQUIPMENT DIMENSIONS

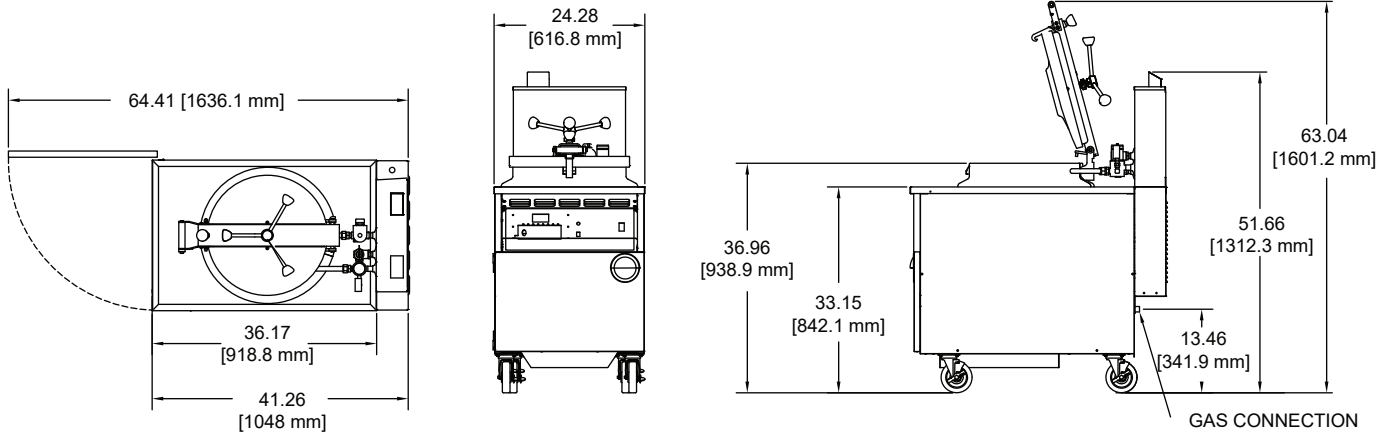

MECHANICAL SPECIFICATIONS

Dimensions	Uncrated	Crated
Height	51 11/16" (1312.3 mm)	60" (1524 mm)
Width	24 5/16" (616.8 mm)	31" (787 mm)
Depth	41 1/4" (1048 mm)	45" (1143 mm)
Floor space	7.0 sq ft (.65 sq m)	7.9 sq ft (.73 sq m)
Weight	440 lb (199.6 kg)	445 lb (202 kg)

ELECTRICAL OPTIONS

Volts	Amps	kW	Wires & Grnd	Phase
120/60Hz	5.6	6	2	1

GAS OPTIONS

	BTU/hr	Inlet Pressure
Nat or LP	70,000	MIN. 4" W.C. / MAX. 14" W.C.

CLEARANCES

Front	Sides	Rear
24"	0"	6"

OPERATING PRESSURE

Operating PSI	12 PSI
Safety Release PSI	15 PSI

GAS CONNECTION

3/4" NPT

INCLUDED ACCESSORIES

- 1 White pot scrubber brush
- 1 White drain brush
- 1 L-tipped brush
- 1 Long black brush
- 1 Short black brush
- 1 Bail handle basket
- 1 Pair 13" insulated mitts
- 5 Filter paper



Visit www.bkideas.com to view all accessories available with this model.