



X-LARGE VOLUME DEEP FRYER - AUTO-LIFT -
TOUCHPAD CONTROLS - FILTER SYSTEM - ELECTRIC OPERATION

Model BLF-FC



This extra-large electric auto-lift fryer is designed for simple operation, long life, and high product volume. The process controls are easy to use and program for true one-touch cooking. The BKI® BLF-FC fryer cooks up to 18 lb (8.2 kg) of product in one cycle and holds 75 lb (34 kg) of oil.

Open-vat fryers are perfect for producing extra-crispy exteriors and tender interiors on a variety of fried foods. The auto-lift basket ensures that food is removed from the oil at the precise moment it is completely cooked. The auto-lift feature also keeps employees away from hot splattering oil. Combine this fryer with a BKI warmer and your food will be hot and crispy for hours!

The amazing efficiency and fast recovery times of the BLF series electric fryers are realized by the placement of the heating elements completely inside the vat with oil flowing freely around them.

The semi-automatic filtration system keeps oil fresh and extends its usable life. This saves you money over the life of the fryer and keeps your food tasting consistent every time. A built-in cold zone in the vat collects breading fall-off, keeping oil fresh and clean. With the push of a button and the twist of a handle, filtering oil is easy and safe. The patented quick-disconnect allows for easy removal of the filtering vat.

FEATURES AT A GLANCE

- 18 lb (8.2 kg) product, 75 lb (34 kg) oil capacity
- Auto-lift basket for precise cooking
- 5" casters for easy mobility
- Stainless steel construction
- Microprocessor controlled for enhanced cooking capabilities
- Automatic, quick-disconnect
- filter system
- 100% hand built in the U.S.A.

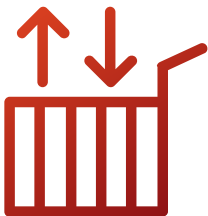

AUTO-LIFT BASKET

The auto-lift basket feature pulls the product from the oil when the cook cycle is complete.



ELECTRIC OPERATION

Energy efficiency and easy installation are a perfect pairing for your food service operation.



TOUCHPAD CONTROLS

Touchpad controls are easy to use and ensure menu items are perfectly cooked.

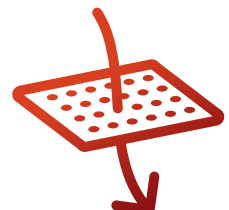

SEMI-AUTO FILTRATION

Semi-automatic filtration system filters after every batch without operator input.

www.bkideas.com

42 Allen Martin Drive, Essex Junction, VT 05452 • Phone: (802) 658-6600 • Fax: (802) 864-0183

BK1261 Rev D (4/25)

EQUIPMENT DIMENSIONS

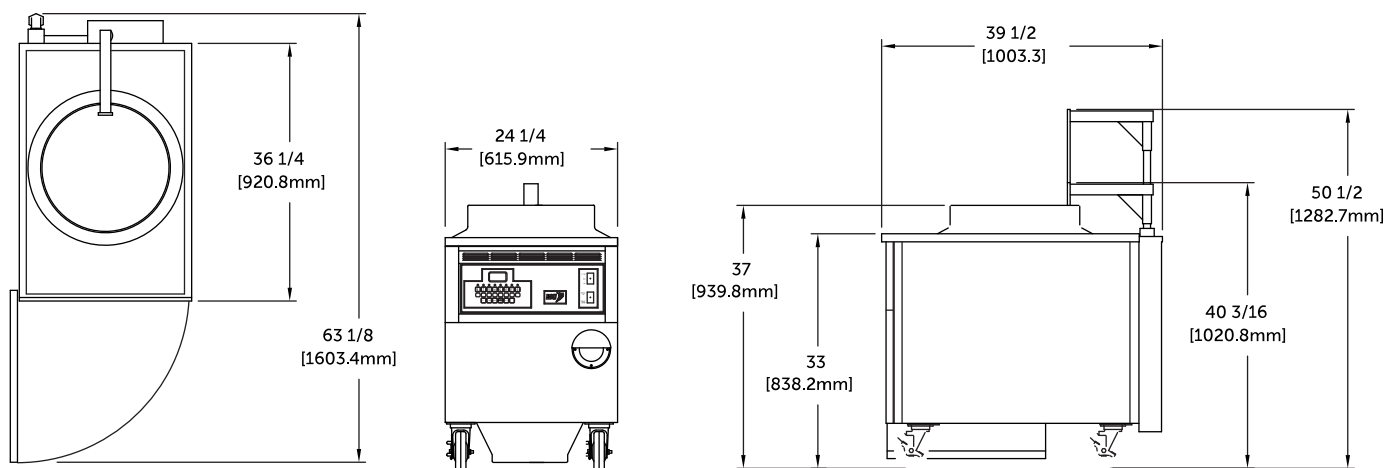

MECHANICAL SPECIFICATIONS

Dimensions	Uncrated	Crated
Height	40 3/16" (1020.8 mm)	60" (1524 mm)
Width	24 1/4" (615.9 mm)	31" (787 mm)
Depth	39 1/2" (1003.3 mm)	45" (1143 mm)
Floor space	6.7 sq ft (.62 sq m)	7.9 sq ft (.73 sq m)
Weight	325 lb (147.4 kg)	335 lb (152 kg)

ELECTRICAL OPTIONS

Volts	Amps	Breaker	kW	Wires	Phase
208	47.3	60	17	3	3
220	37.5	50	14.3	3	3
240	41	50	17	3	3
220/380	21.7	30	14.3	4	3
230/400	22.8	30	15.6	4	3
240/415	23.7	30	17	4	3

INCLUDED ACCESSORIES

- Bail handle basket
- 1 L-tipped brush
- 1 White drain brush
- 1 Pair 13" insulated mitts
- 5 Filter Paper



Visit www.bkideas.com to view all accessories available with this model.