



Mobile Hot Food Merchandiser Series

Series: MHB

Operation Manual



BKI LIMITED WARRANTY

2812 Grandview Drive • Simpsonville, SC 29680 • USA
(864) 963-3471 • Toll Free: (800) 927-6887 • Fax: (864) 963-5316

WHAT IS COVERED

This warranty covers defects in material and workmanship under normal use, and applies only to the original purchaser providing that:

- ⌘ The equipment has not been accidentally or intentionally damaged, altered or misused;
- ⌘ The equipment is properly installed, adjusted, operated and maintained in accordance with national and local codes, and in accordance with the installation and operating instructions provided with this product.
- ⌘ The serial number rating plate affixed to the equipment has not been defaced or removed.

WHO IS COVERED

This warranty is extended to the original purchaser and applies only to equipment purchased for use in the U.S.A.

COVERAGE PERIOD

- ⌘ Warranty claims must be received in writing by BKI within one (1) year from date of installation or within one (1) year and three (3) months from data of shipment from the factory, whichever comes first.
- ⌘ COB Models: One (1) Year limited parts and labor.
- ⌘ COM Models: Two (2) Year limited parts and labor. COM convection ovens also have a two (2) year door warranty.
- ⌘ Warranty period begins the date of dealer invoice to customer or ninety (90) days after shipment date from BKI, whichever comes first.

WARRANTY COVERAGE

This warranty covers on-site labor, parts and reasonable travel time and travel expenses of the authorized service representative up to (100) miles round trip and (2) hours travel time and performed during regular, weekday business hours.

EXCEPTIONS

Any exceptions must be pre-approved in advance and in writing by BKI.

EXCLUSIONS

- ⌘ Negligence or acts of God,
- ⌘ Thermostat calibrations after (30) days from equipment installation date,
- ⌘ Air and gas adjustments,
- ⌘ Light bulbs,
- ⌘ Glass doors and door adjustments,
- ⌘ Fuses,
- ⌘ Adjustments to burner flames and cleaning of pilot burners,
- ⌘ Tightening of screws or fasteners,
- ⌘ Failures caused by erratic voltages or gas suppliers,
- ⌘ Unauthorized repair by anyone other than a BKI Factory Authorized Service Center,
- ⌘ Damage in shipment,
- ⌘ Alteration, misuse or improper installation,
- ⌘ Thermostats and safety valves with broken capillary tubes,
- ⌘ Freight - other than normal UPS charges,
- ⌘ Ordinary wear and tear,
- ⌘ Failure to follow installation and/or operating instructions,
- ⌘ Events beyond control of the company.

INSTALLATION

Leveling, as well as proper installation and check out of all new equipment - per appropriate installation and use materials - is the responsibility of the dealer or installer, not the manufacturer.

REPLACEMENT PARTS

BKI genuine Factory OEM parts receive a (90) day materials warranty effective from the date of installation by a BKI Factory Authorized Service Center.

Warranty is in lieu of all other warranties, expressed or implied, and all other obligations or liabilities on the manufacturer's part. BKI shall in no event be liable for any special, indirect or consequential damages, or in any event for damages in excess of the purchase price of the unit. The repair or replacement of proven defective parts shall constitute a fulfillment of all obligations under the terms of this warranty.

Table of Contents

Table of Contents	1
Introduction.....	2
Safety Precautions	2
Safety Signs and Messages	2
Safe Work Practices	3
Safety Labels	4
Operation.....	5
Controls and Indicators	5
Hardware Controls.....	5
Preheating.....	6
Temperature Adjustment.....	6
Operational Guidelines.....	6
Unit Shutdown.....	6
Installation.....	7
Unpacking and Handling	7
Location.....	7
Wiring Connection And Grounding.....	7
General Guidelines	7
Mechanical Specifications	8
Maintenance.....	9
Scheduled Maintenance.....	9
Cleaning.....	9
Troubleshooting	11
Accessories	12
Wiring Diagrams	13
MHB-3	13
MHB-4	14
MHB-5	15
Notes.....	16

Introduction

NOTICE

PLEASE READ THIS ENTIRE MANUAL BEFORE SERVICING THE UNIT. If you have any questions, contact the BKI Technical Service Department, toll free: 1-800-927-6887. Outside the U.S., call 1-864-963-3471.

Safety Precautions

Always follow recommended safety precautions listed in this manual. Below is the safety alert symbol. When you see this symbol on your equipment, be alert to the potential for personal injury or property damage.

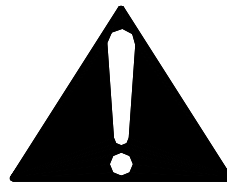

Safety Signs and Messages

The following Safety signs and messages are placed in this manual to provide instructions and identify specific areas where potential hazards exist and special precautions should be taken. Know and understand the meaning of these instructions, signs, and messages. Damage to the equipment, death or serious injury to you or other persons may result if these messages are not followed.

⚠ DANGER

This message indicates an imminently hazardous situation which, if not avoided, will result in death or serious injury.

⚠ WARNING

This message indicates a potentially hazardous situation, which, if not avoided, could result in death or serious injury.

⚠ CAUTION

This message indicates a potentially hazardous situation, which, if not avoided, may result in minor or moderate injury. It may also be used to alert against unsafe practices.

NOTICE

This message is used when special information, instructions or identification are required relating to procedures, equipment, tools, capacities and other special data.

Safe Work Practices



Beware of High Voltage

This equipment uses high voltage. Serious injury can occur if any untrained or unauthorized person installs, services, or repairs this equipment. Advise your customer to always use an Authorized Service agent to Service this Equipment



California Residents Only. This product can expose you to chemicals including chromium, and lead which are known to the State of California to cause cancer and birth defects or other reproductive harm. For more information go to www.P65Warnings.ca.gov.

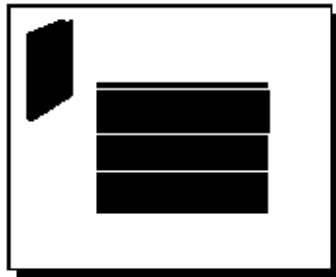

Your Customer Should have an Operators Manual

The operator's manual is an important part of this equipment. Your customer should keep it near for easy access.

If your customer needs a replacement operator's manual, contact:

BKI

Technical Services Department
2812 Grandview Dr.
Simpsonville, S.C. 29680
Or call toll free: 1-800-927-6887
Outside the U.S., call 864-963-3471

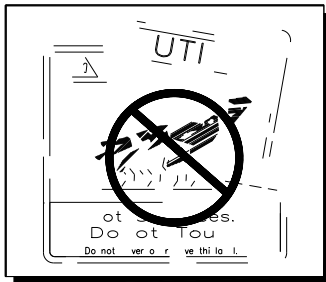

Safety Labels Must be Clean and in Good Condition

Make sure all safety labels are in place, clean and in good condition. Replace any damaged or missing safety labels.

If you need new safety labels, contact:

BKI

Technical Services Department
2812 Grandview Dr.
Simpsonville, S.C. 29680
Or call toll free: 1-800-927-6887
Outside the U.S., call 864-963-3471

Safety Labels

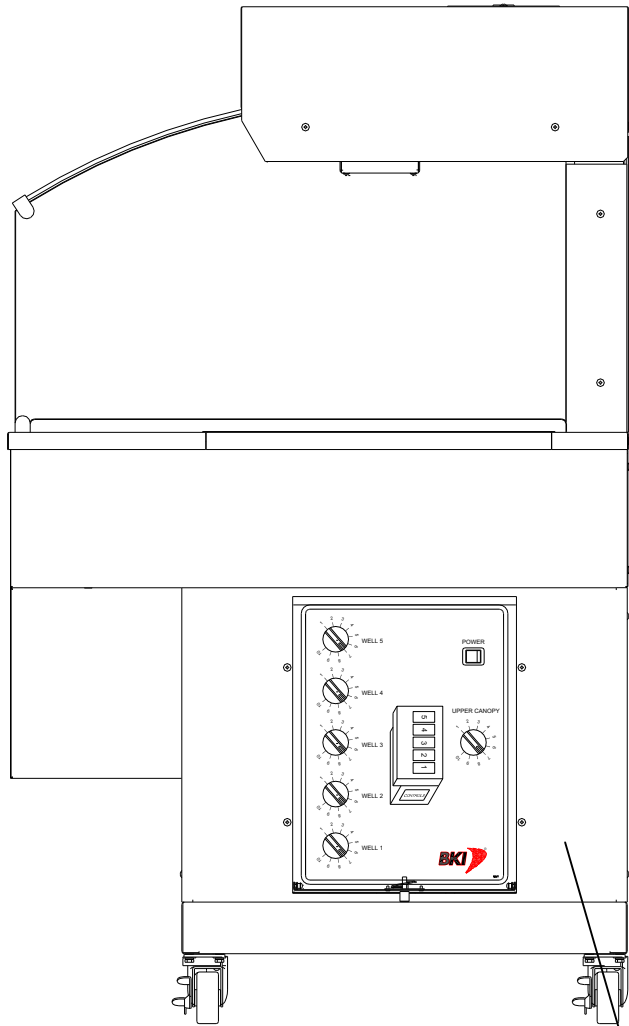

N0202



Operation

Controls and Indicators

The mobile hot bar controls are shown in the figure below. The rocker switch turns the power supply to the unit on and off. The temperature controls adjust the temperature of the well and overhead heating elements.

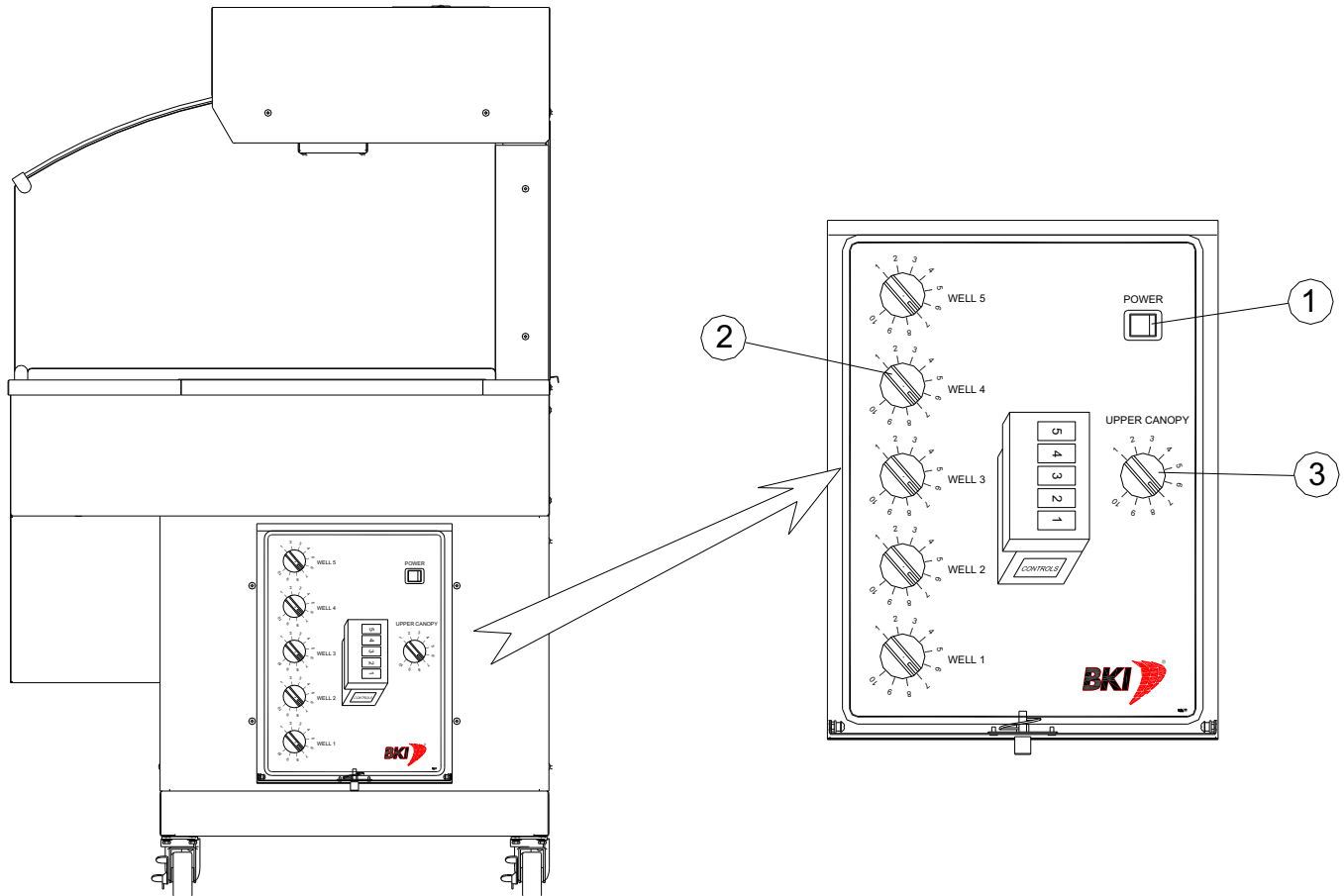

Hardware Controls

Item #	Description	Function
1	Main Power Switch	Turns power On or Off to the entire unit. When placed in the on position, the well and overhead heaters are powered and the lights illuminate. When placed in the off position, power is removed from the entire unit.
2	Individual Well Thermostats	Controls the temperature of the specific well as shown on the well diagram. Rotate clockwise to increase the temperature and counter clockwise to decrease the temperature.
3	Overhead Heaters Infinite Switch.	Controls the temperature of all of the overhead heaters in the canopy. Rotate clockwise to increase the temperature and counter clockwise to decrease the temperature.

Preheating

You should allow the unit to preheat for a minimum of 30 minutes before loading it with product. The recommended initial setting for the well thermostats is 7 and for the upper canopy heaters is 7.

Temperature Adjustment

After placing the product into the hot bar, it may be necessary to adjust the thermostat settings in order to maintain the proper internal temperature for the product on display.

Measure the product internal temperature every 30 minutes by inserting a food thermometer into the food. The internal temperature of the food should be no less than 140°F [60°C]. Most areas of the country have regulations governing the minimum temperature for hot foods. Make certain to check with your local authorities.

If necessary adjust the thermostat settings to maintain the proper internal temperature of the food product. The thermostats should be set to the lowest possible setting that will maintain the proper product temperature.

Operational Guidelines

Foods should be a minimum of 175° F [80° C] before being placed in the unit.

Keep food thermometer on hand. Check the food temperatures every 30 minutes

Rotate the food products. Foods loaded in first should be served first as much as is practical.

Foods held for long periods of time are more difficult to maintain at proper temperature. Also, freshness and product quality diminish if foods are held too long. Most areas of the country have sanitation regulations governing how long foods can be held. Make certain to check with your local authorities.

Unit Shutdown

Remove all food pans holding the food product from the unit. Move the rocker switch to the **OFF** position to turn the power to the heaters and lights off. After the temperature has cooled below **120°F (50°C)**, remove any residue from the well and clean the equipment thoroughly.

Installation

⚠ WARNING

Serious injury, equipment damage or death could result if attempting to install this unit yourself. Ensure that an authorized BKI service agent installs the unit.

Unpacking and Handling

The company taking delivery of this equipment is responsible for filing all freight claims with the delivering truck line. Inspect all cartons and crates for damage as soon as they arrive. If damage to cartons or crates is found, or if a shortage is found, note this on the bill of lading (all copies) prior to signing.

If damage is found when the equipment is opened, immediately call the delivering truck line and follow up the call with a written report indicating concealed damage to your shipment. Ask for an immediate inspection of your concealed damage item. Packaging material **MUST** be retained to show the inspector from the truck line.

⚠ WARNING

Do not walk on top of the equipment or damage to the equipment and serious personal injury could occur. The equipment is not structurally designed to support excessive external loading such as the weight of a person. Do not place heavy objects on the equipment.

Move the unit as close as possible to its permanent location before moving the unit off of the shipping pallet.

Make certain there are no separately packed accessories before discarding packaging.

Location

The unit must be located on a level surface. After moving the unit, be sure to lock all 4 casters on the unit.

Wiring Connection and Grounding

⚠ WARNING

Electrocution, equipment failure or property damage could result if an unlicensed electrician performs the electrical installation. Ensure that a licensed electrician performs the electrical installation in accordance with local codes, or in the absence of local codes, with the National Electrical Code, ANSI NFPA 70-20XX.

Cord entry knockouts are provided on the top and bottom of the unit. Refer to the Mechanical Specifications section of this manual for the location of these knockouts.

Refer to the Wiring Diagrams in this manual for the proper 1 or 3 phase connections for the specific model being installed. Install the provided terminal block jumpers in the terminal block that the field wiring connections are being made to as shown in the appropriate wiring diagram.

General Guidelines

In the absence of local codes refer to the latest edition of one of the following:

National Electrical Code, ANSI/NFPA 70-20XX (USA) which can be obtained from:

The National Fire Protection Association
Batterymarch Park
Quincy, MA 02269

Verify that the power supply conforms to the electrical rating listed on the data plate.

Ensure that the appliance is grounded (earthed).

Mechanical Specifications

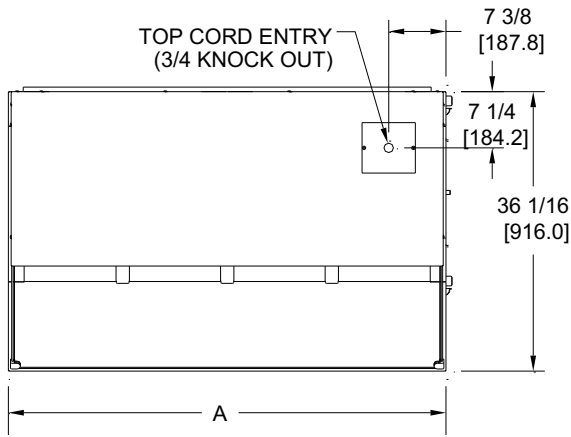

MODEL	WELLS	DIM. "A"
MHB-3	3	43 [1092]
MHB-4	4	56 1/2 [1435]
MHB-5	5	70 [1778]

MODEL	208V		220V		240V	
	kW	Amps*	kW	Amps*	kW	Amps*
MHB-3	3.3	10.7/15.9	3.2	10.0/14.7	3.8	10.9/16.0
MHB-4	4.4	12.5/21.1	4.3	11.5/19.5	5.1	12.5/21.2
MHB-5	6.2	18.7/29.9	6.0	16.2/27.4	7.2	17.7/29.8

* ALL MODELS ARE 3 or 1 Ph
 AMPS SHOWN ARE 3 Ph/ 1 Ph

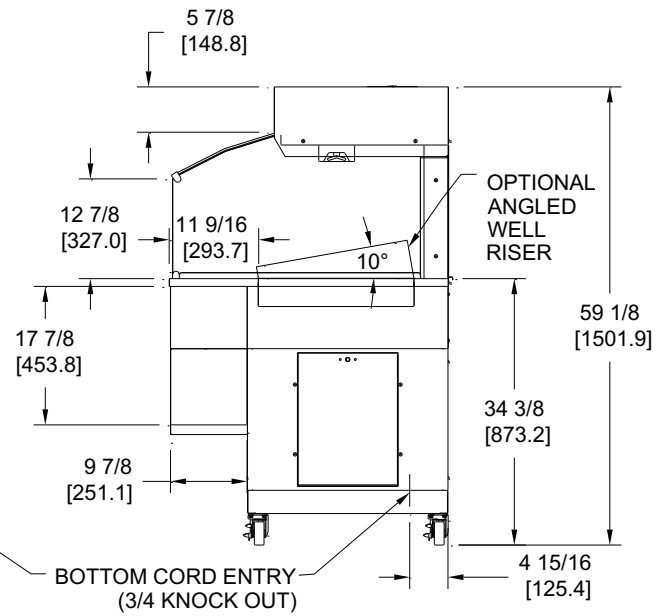
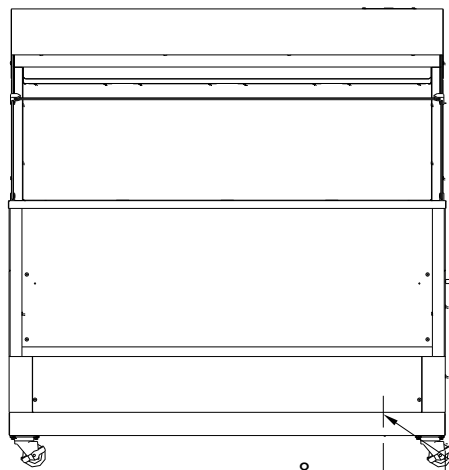

Maintenance

⚠ CAUTION

Failure to comply with the maintenance below could result in a serious accident.

⚠ WARNING

Electrocution, equipment failure or property damage could result if an unlicensed electrician performs electrical repair. Ensure that a licensed electrician performs electrical repair.

Scheduled Maintenance

Use the following table to help manage scheduled maintenance activities.

Frequency	Performed By	Part	Activity
Daily	User	Mobile Hot Bar	Clean the entire unit. Refer to the cleaning procedure below.

Cleaning

This unit should be cleaned at the end of each day. Use the following procedure:

⚠ DANGER

Failure to remove power from this unit may cause severe electrical shock. This unit may have more than one disconnect switch.

1. Turn the unit **OFF** and allow it to cool down.
2. Remove any food from unit.
3. If so equipped, unplug the cord from the receptacle.
4. Allow the equipment to cool to room temperature.

⚠ CAUTION

Using abrasive cleaners may damage the cabinet finish. Use only a mild soap and water solution.

Never steam clean or get excess water in the interior of the cabinet as this can damage unit.

This appliance is not intended to be cleaned with a water jet.

NOTICE

Never use cleaners containing ammonia (Windex, 409, etc.) on the clear plastic parts of the unit. Ammonia will damage these parts.

Never use a dry cloth or your hands to remove dirt and dust from the clear plastic parts. This will scratch the parts.

Use a mild soap and water solution or products specifically intended for cleaning plastic (Novus #1, Brillianize, etc.) and a soft cloth to clean the clear plastic parts.

After cleaning, rinse the clear plastic parts with clean water. Dry with a soft cloth to prevent water spotting.

5. Clean the stainless steel well and exterior surfaces with warm water, a sponge and a cleaner that is approved for use on food surfaces.

NOTE: For ease of cleaning the solid back panel can be removed from the unit. Refer to the Solid Back Panel Removal diagram below.

6. Wipe the stainless steel well and exterior parts dry with a soft, clean cloth.
7. Clean any clear plastic sneeze guards and end panels as described above.

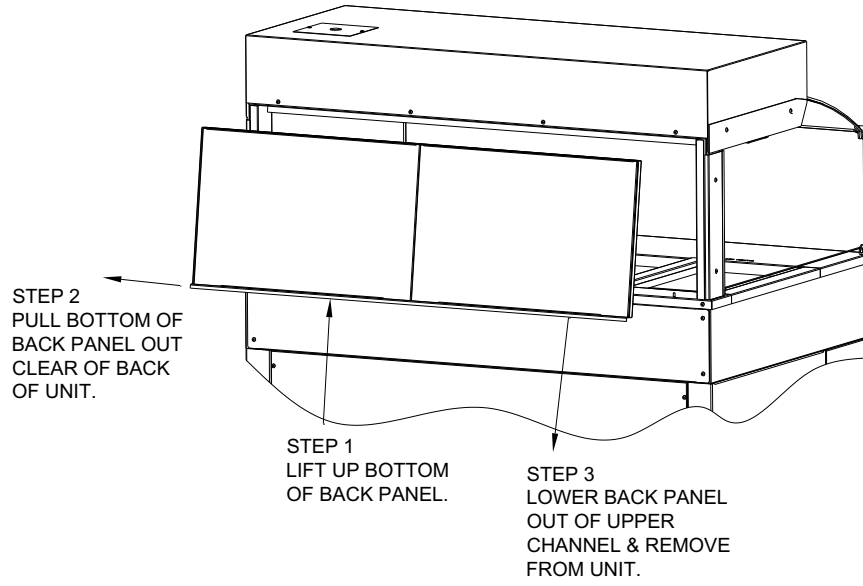

MHB SOLID BACK PANEL REMOVAL

Troubleshooting

Refer to the table below for troubleshooting information.

Disconnect the merchandiser power supply by unplugging the cord before performing any diagnostic testing.

Problem	Cause	Possible Solution
Unit Not Operating	No Power to the unit.	Check circuit breaker or fuses at building power panel.
	Power switch is off.	Reset the power switch.
Holding Temperature Not Adequate	Unit has not been preheated.	Refer to the Preheating section of this manual.
	Product is below temperature when loaded into merchandiser.	Check product temperature before loading the merchandiser.
	Well or Upper Canopy thermostat setting too low.	Refer to Temperature Adjustment section of this manual.
	One or more heating elements not operating properly.	Contact authorized BKI service company.
Light Bulb(s) Do Not Illuminate when Power is turned On	Failed Light Bulb(s)	Replace failed Light Bulb(s). To maintain NSF compliance, replace only with genuine BKI replacement lamps.
	Blown Fuse	Contact authorized BKI service company.
	Failed Ballast	Contact authorized BKI service company.

Accessories

Angled Well Riser (WB64406500) – Accommodates 2 1/2" or 4" full size steam table pans.

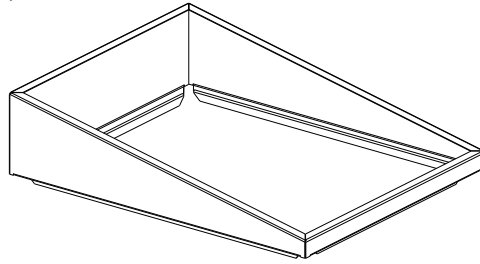

End Shelves (Consult Factory) – Available on either or both ends of the hot bar. Designed to meet your specific merchandising requirements.

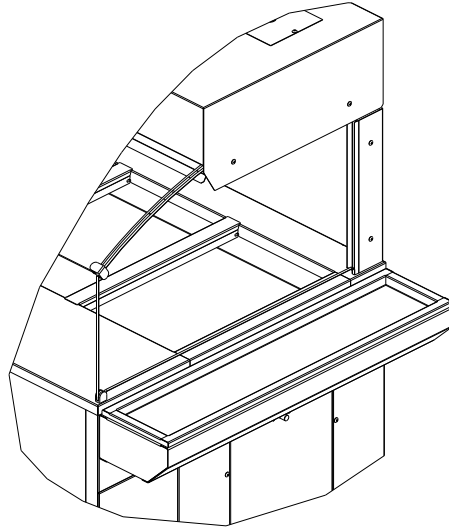

End Shelf with Removable Tray shown.

Wiring Diagrams

MHB-3

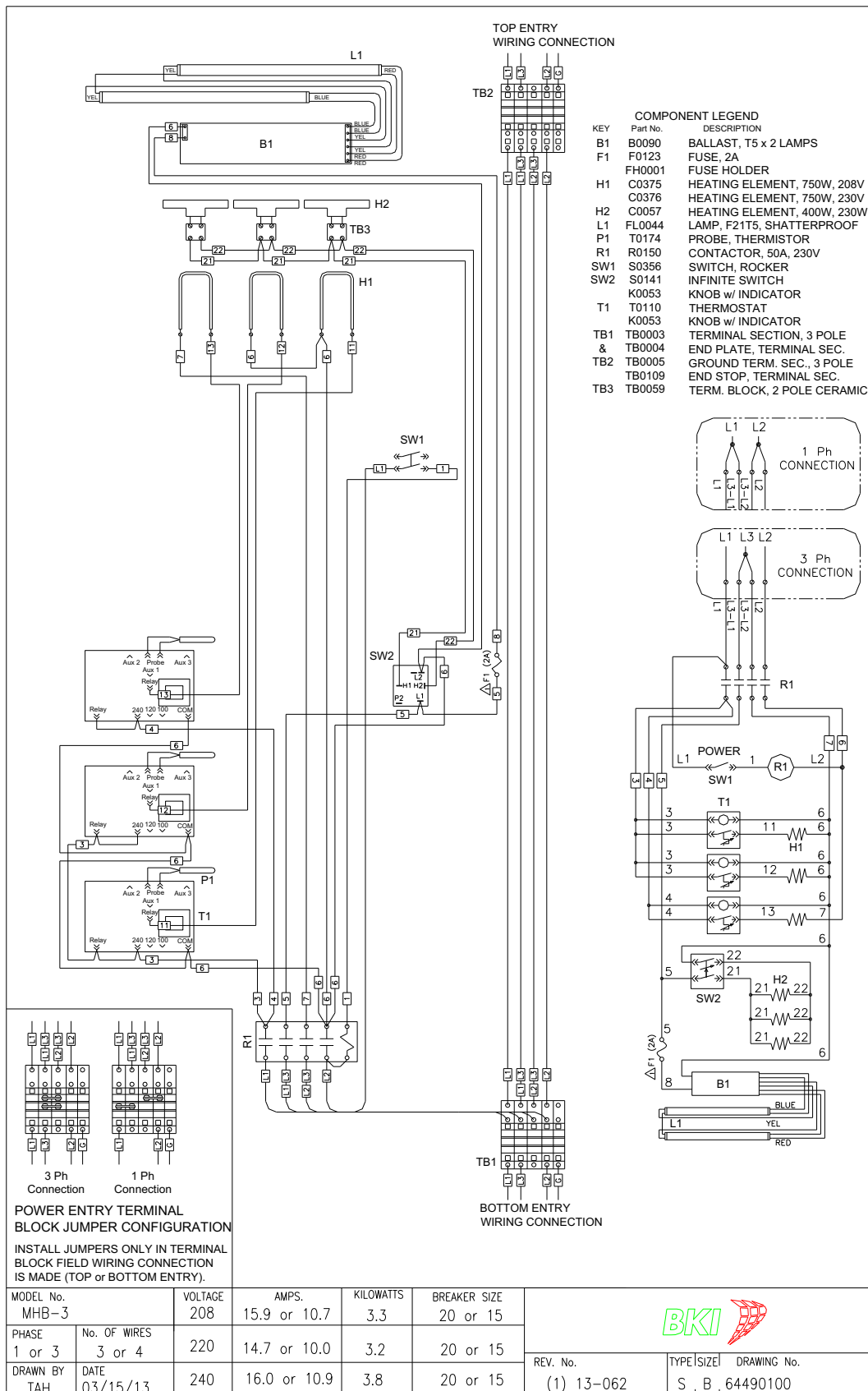

REV. No. (1) 13-062 TYPE SIZE S B DRAWING No. 64490100

MHB-4

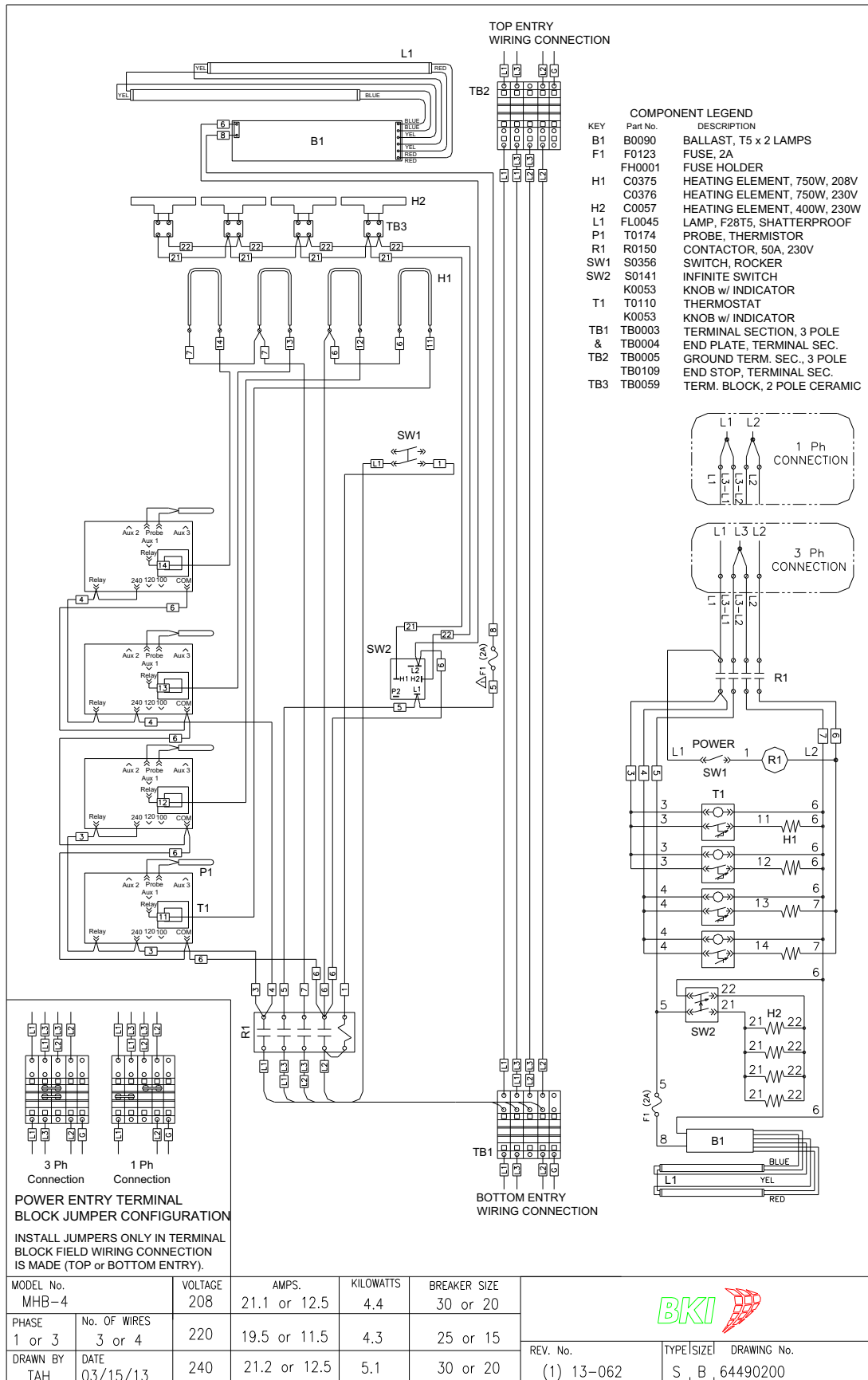

MODEL No.	VOLTAGE	AMPS.	KILOWATTS	BREAKER SIZE
MHB-4	208	21.1 or 12.5	4.4	30 or 20
PHASE 1 or 3	No. OF WIRES 3 or 4	220	19.5 or 11.5	4.3
DRAWN BY TAH	DATE 03/15/13	240	21.2 or 12.5	5.1

REV. No. (1) 13-062

TYPE | SIZE | DRAWING No.
S, B, 64490200

MHB-5

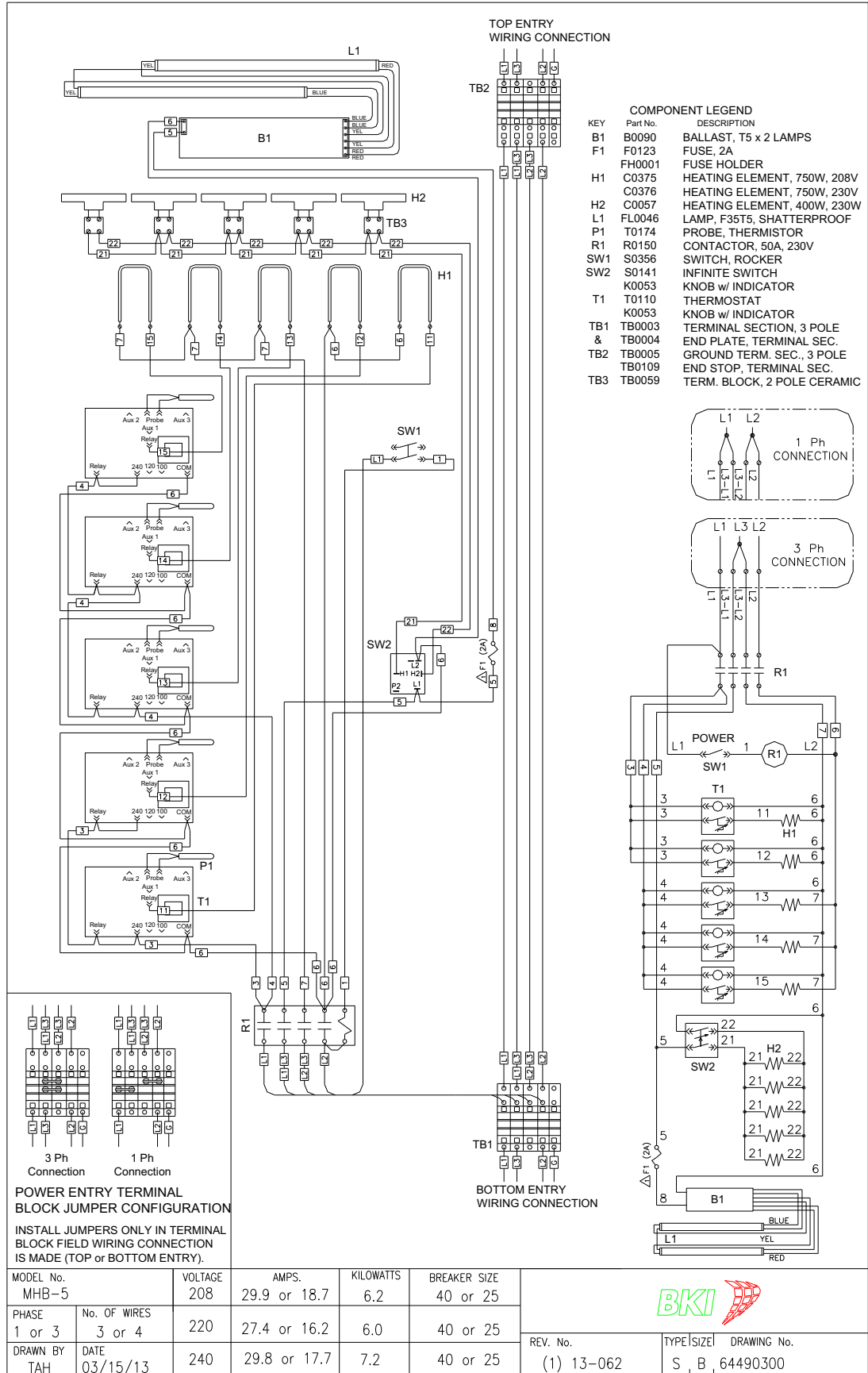

MODEL No.	VOLTAGE	AMPS.	KILOWATTS	BREAKER SIZE
MHB-5	208	29.9 or 18.7	6.2	40 or 25
PHASE 1 or 3	No. OF WIRES 3 or 4	220	27.4 or 16.2	6.0
DRAWN BY TAH	DATE 03/15/13	240	29.8 or 17.7	7.2

REV. No. (1) 13-062

TYPE | SIZE | DRAWING No.
S, B 64490300

Notes



2812 Grandview Dr., Simpsonville, S.C. 29680, USA
<http://www.bkideas.com>

Made and printed in the U.S.A

REVISION HISTORY

REVISION	DATE	REVISED BY	DESCRIPTION
01	04/29/13	TAH	Initial Release-Supersedes all previous releases.
02	5/20/13	TAH	Revise wiring diagrams for added light circuit fuse, and make grammatical corrections where necessary.
03	10/1/2018	KW	Added P65 Warning and note that BKI is a subsidiary of Standex Int'l Corp.