



X-Large, Double-Rotating Rotisserie Oven Series

Series: DRGV with TouchTEC controls
Operation Manual



Gas Rotisserie Oven

MODEL DRGV (with TouchTEC Controller)

Service Manual

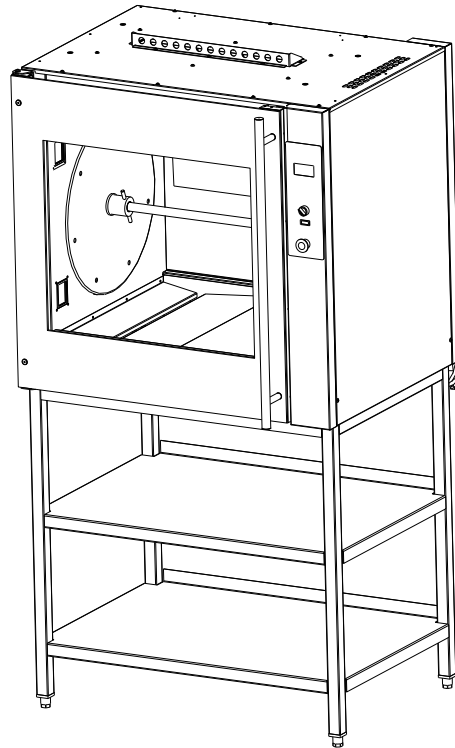

NOTICE

The purchaser must post, in a prominent location, instructions to be followed in the event the user smells gas. This information shall be obtained by consulting the local gas supplier.

WARNING

Improper installation, adjustment, alteration, service or maintenance can cause property damage, injury or death. Read the installation, operation and maintenance instructions thoroughly before installing or servicing this equipment.

FOR YOUR SAFETY

Do not store or use gasoline or other flammable vapors or liquids in the vicinity of this or any other appliance.



Fresh ideas in foodservice equipment

BKI LIMITED WARRANTY

2812 Grandview Dr. • Simpsonville, SC 29680 • USA
(864) 963-3471 • Toll Free: (800) 927-6887 • Fax: (864) 963-5316

WHAT IS COVERED

This warranty covers defects in material and workmanship under normal use, and applies only to the original purchaser providing that:

- The equipment has not been accidentally or intentionally damaged, altered or misused;
- The equipment is properly installed, adjusted, operated and maintained in accordance with national and local codes, and in accordance with the installation and operating instructions provided with this product.
- The serial number rating plate affixed to the equipment has not been defaced or removed.

WHO IS COVERED

This warranty is extended to the original purchaser and applies only to equipment purchased for use in the U.S.A.

COVERAGE PERIOD

- Warranty claims must be received in writing by BKI within one (1) year from date of installation or within one (1) year and three (3) months from data of shipment from the factory, whichever comes first.
- COB Models: One (1) Year limited parts and labor.
- COM Models: Two (2) Year limited parts and labor. COM convection ovens also have a two (2) year door warranty.
- CO1 Models: Two (2) Year limited parts and labor. Five (5) Year limited door warranty.
- BevLes Products: Two (2) Year limited parts and labor.
- Warranty period begins the date of dealer invoice to customer or ninety (90) days after shipment date from BKI, whichever comes first.

WARRANTY COVERAGE

This warranty covers on-site labor, parts and reasonable travel time and travel expenses of the authorized service representative up to (100) miles round trip and (2) hours travel time and performed during regular, weekday business hours.

EXCEPTIONS

Any exceptions must be pre-approved in advance and in writing by BKI. The extended door warranty on convection ovens years 3 through 5 is a parts only warranty and does not include labor, travel, mileage or any other charges.

EXCLUSIONS

- Negligence or acts of God,
- Thermostat calibrations after (30) days from equipment installation date,
- Air and gas adjustments,
- Light bulbs,
- Glass doors and door adjustments,
- Fuses,
- Adjustments to burner flames and cleaning of pilot burners,
- Tightening of screws or fasteners,
- Failures caused by erratic voltages or gas suppliers,
- Unauthorized repair by anyone other than a BKI Factory Authorized Service Center,
- Damage in shipment,
- Alteration, misuse or improper installation,
- Thermostats and safety valves with broken capillary tubes,
- Freight - other than normal UPS charges,
- Ordinary wear and tear,
- Failure to follow installation and/or operating instructions,
- Events beyond control of the company.

INSTALLATION

Leveling, as well as proper installation and check out of all new equipment - per appropriate installation and use materials - is the responsibility of the dealer or installer, not the manufacturer.

REPLACEMENT PARTS

BKI genuine Factory OEM parts receive a (90) day materials warranty effective from the date of installation by a BKI Factory Authorized Service Center.

Warranty is in lieu of all other warranties, expressed or implied, and all other obligations or liabilities on the manufacturer's part. BKI shall in no event be liable for any special, indirect or consequential damages, or in any event for damages in excess of the purchase price of the unit. The repair or replacement of proven defective parts shall constitute a fulfillment of all obligations under the terms of this warranty.

Table of Contents

Table of Contents	1
Introduction.....	2
Safety Precautions	2
Safety Signs and Messages	2
Specific Precautions	2
Safe Work Practices	4
Safety Labels	5
Health and Sanitation Practices	5
Food Handling.....	6
Storage of Raw Meats	6
Coding Cooked Foods	6
Storage of Prepared Foods	6
Operation.....	7
Controls and Indicators	7
Hardware Controls	7
Software Controls – Operation Screens	8
Software Controls – Programming Screens	10
Programming the Controller Using the Touchscreen Interface.....	12
Edit a Recipe.....	12
Edit the Basic Setup.....	12
Operation with the Controller	13
Viewing Recipes	13
Cooking.....	13
Operation After a Gas or Power Outage.....	14
Normal Shutoff	14
Installing Rotor System	14
Preparing and Loading Chickens	14
Trussing Chickens	15
V-Spits	16
Baskets	17
Installation.....	18
Unpacking and Handling	18
Location and Clearance	18
Specific Instructions	18
Counter Top and Stand.....	19
Mounting.....	20
Stacking Ovens	22
Locking Ovens in Place.....	27
Gas Supply Connection	28
Gas Manifold Pressure Test.....	28
Maintenance.....	29
Scheduled Maintenance.....	29
Daily Cleaning & Maintenance.....	29
Troubleshooting.....	32
Accessories.....	35
Replacement Parts	36
Wiring Diagram	41
Notes.....	42

Introduction

Your **BKI** DRGV is a computer controlled gas rotisserie oven. It utilizes a double revolving mechanism and infrared burner that ensure even product cooking. A touchscreen control and switches are provided to allow for quick setup and operation. Removable components allow for easy maintenance and cleaning.

The **BKI** name and trademark on this unit assures you of the finest in design and engineering -- that it has been built with care and dedication -- using the best materials available. Attention to the operating instructions regarding proper installation, operation, and maintenance will result in long lasting dependability to ensure the highest profitable return on your investment.

NOTICE

PLEASE READ THIS ENTIRE MANUAL BEFORE OPERATING THE UNIT. If you have any questions, please contact your BKI Distributor. If they are unable to answer your questions, phone the applicable BKI Technical Services Department:

BKI North America: (864) 963-3471

Safety Precautions

Always follow recommended safety precautions listed in this manual. Below is the safety alert symbol. When you see this symbol on your equipment, be alert to the potential for personal injury or property damage.

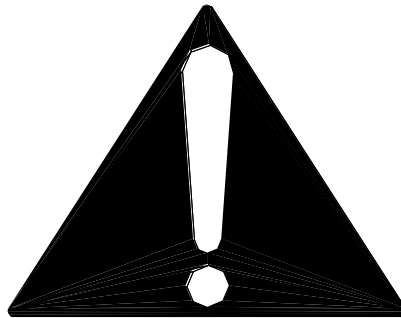

Safety Signs and Messages

The following Safety signs and messages are placed in this manual to provide instructions and identify specific areas where potential hazards exist and special precautions should be taken. Know and understand the meaning of these instructions, signs, and messages. Damage to the equipment, death or serious injury to you or other persons may result if these messages are not followed.

DANGER

This message indicates an imminently hazardous situation which, if not avoided, will result in death or serious injury.

WARNING

This message indicates a potentially hazardous situation, which, if not avoided, could result in death or serious injury.





CAUTION

This message indicates a potentially hazardous situation, which, if not avoided, may result in minor or moderate injury. It may also be used to alert against unsafe practices.

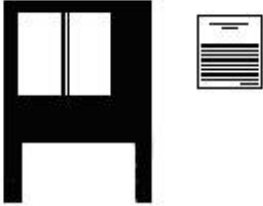

NOTICE

This message is used when special information, instructions or identification are required relating to procedures, equipment, tools, capacities and other special data.

Specific Precautions

<p>NOTICE</p>	<p>The purchaser must post, in a prominent location, instructions to be followed in the event the user smells gas. This information shall be obtained by consulting the local gas supplier.</p>
<p>⚠ WARNING</p>	<p>FOR YOUR SAFETY Do not store or use gasoline or other flammable vapors or liquids in the vicinity of this or any other appliance</p>
<p>⚠ WARNING</p>	<p>Improper installation, adjustment, alteration, service or maintenance can cause property damage, injury or death. Read the installation, operation and maintenance instructions thoroughly before installing or servicing this equipment.</p>
	<p>Use Gas Safely-- Avoid Danger Gas can be a dangerous fuel if not handled safely. Make sure to ventilate the oven properly. If the oven is not properly ventilated, carbon monoxide can be released around the oven. Asphyxiation or suffocation can occur if gas is not ventilated properly.</p>
	<p>Clearance to Combustibles Observe proper clearance to combustibles as noted on the oven rating tag. Never place anything on top of the oven. Keep the area around the oven free and clear from combustibles.</p>
	<p>WARNING – DANGEROUS VOLTAGE This equipment uses high voltage. Serious injury can occur if you or any untrained or unauthorized person installs, services, or repairs this equipment. Always Use an Authorized Service agent to Service Your Equipment.</p>
	<p>Do Not Smoke Near the Oven This oven uses combustible fuels to operate. Smoking near this oven could possibly cause a fire. Do not allow anyone to smoke near this oven.</p>
<p>⚠ WARNING</p>	<p>California Residents Only. This product can expose you to chemicals including chromium, and lead which are known to the State of California to cause cancer and birth defects or other reproductive harm. For more information go to www.P65Warnings.ca.gov.</p>

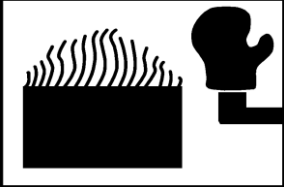
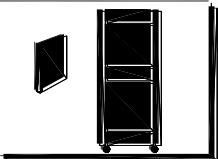
Safe Work Practices

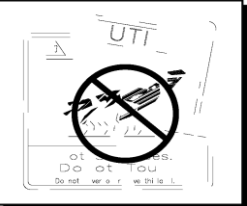
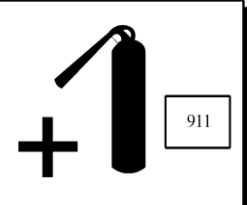
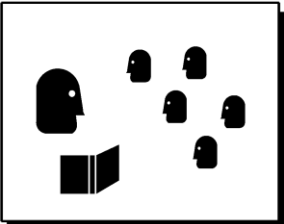
	<p>Wear Safe Clothing Appropriate To Your Job</p> <p>Always wear your insulated mitts when handling hot oven parts or touch any hot metal surface. If you lose or damage your mitts, you can buy new ones at your local restaurant equipment supply store or from your local BKI Distributor.</p> <p>Always wear non-skid shoes when working around the oven or any other equipment.</p> <p>Never wear loose clothing such as neckties or scarves while operating this equipment. Keep loose hair tied back or in a hair net while operating this equipment.</p> <p>Always wear appropriate personal protection equipment during the cleaning process to guard against possible injury.</p>
	<p>Keep this manual with the Equipment</p> <p>This manual is an important part of your equipment. Always keep it near for easy access. If you need to replace this manual, phone the applicable BKI Technical Services Department:</p> <p>BKI North America: (864) 963-3471</p>
	<p>Protect Children</p> <p>Keep children away from this equipment. Children may not understand that this equipment is dangerous for them and others.</p> <p>NEVER allow children to play near or operate your equipment.</p>
	<p>Keep Safety Labels Clean and in Good Condition</p> <p>Do not remove or cover any safety labels on your equipment. Keep all safety labels clean and in good condition. Replace any damaged or missing safety labels. Refer to the Safety Labels section for illustration and location of safety labels on this unit. If you need a new safety label, obtain the number of the specific label illustrated on page 5, then phone the applicable BKI Technical Services Department:</p> <p>BKI North America: (864) 963-3471.</p>
	<p>Be Prepared for Emergencies</p> <p>Be prepared for fires, injuries, or other emergencies.</p> <p>Keep a first aid kit and a fire extinguisher near the equipment. You must use a 40-pound Type BC fire extinguisher and keep it within 25 feet of your equipment.</p> <p>Keep emergency numbers for doctors, ambulance services, hospitals, and the fire department near your telephone.</p>
	<p>Know your responsibilities as an Employer</p> <ul style="list-style-type: none"> • Make certain your employees know how to operate the equipment. • Make certain your employees are aware of the safety precautions on the equipment and in this manual. • Make certain that you have thoroughly trained your employees about operating the equipment safely. <p>Make certain the equipment is in proper working condition. If you make unauthorized modifications to the equipment, you will reduce the function and safety of the equipment.</p>

Safety Labels

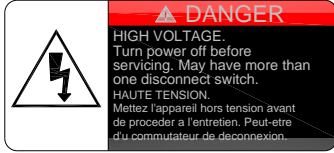

BOTH SIDES of OVEN

CONTROL SIDE of OVEN ONLY

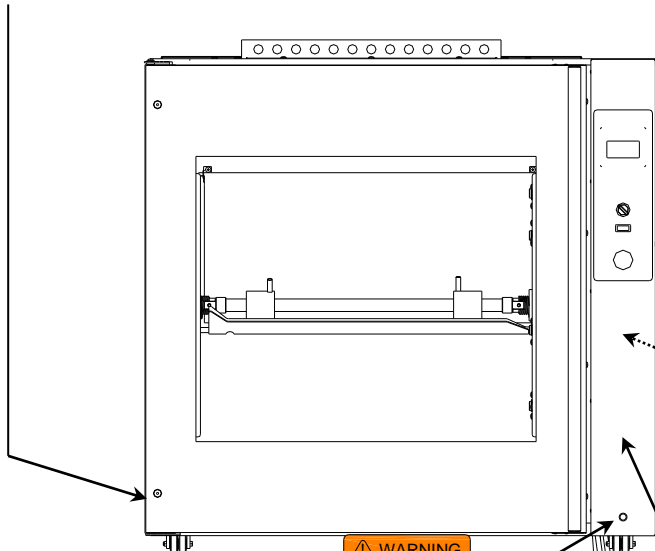

⚠ CAUTION
 Electrical Grounding Instructions - This appliance is equipped with a three-prong (grounding) plug for your protection against shock hazard and should be plugged directly into a properly grounded three-prong receptacle. Do not cut or remove the grounding prong from this plug.
⚠ AVERTIR
 Mise à la terre - Cet appareil est pourvu d'une fiche à trois broches dont une mise à la terre assurant une protection contre les chocs électriques. La prise dans laquelle elle est branchée doit être correctement mise à la terre. Ne pas couper ni enlever la broche de mise à la terre de la fiche.
 DO NOT COVER or REMOVE THIS LABEL. NE RECouvrez PAS ou ENLEVEZ PAS CETTE ÉTIQUETTE

⚠ WARNING
 WHEN LIT UNIT IS MALFUNCTIONING. TURN OFF and CALL FOR SERVICE.

BKI® "Experts In Heat Transfer Technology" **Standex**
 www.bkideas.com
 MODEL DRGV-7 SERIAL NO 123456789012-12345678
 Modèle N° de Serie
 EQUIPPED FOR NATURAL GAS INPUT 72,000 BTU / Hr
 Equipé pour Gaz Energie BTU / H
 MANIFOLD PRESSURE 4.5 INCHES of WATER
 Pression le Collecteur Pouces d'eau
 VOLTS 115 PHASE 1 Hz 60 AMPS / Ampère 2.2
 Minimum spacing to a wall or adjacent unit. Back 6 in.
 L'espacement minimum sur un mur ou unité Arrière 6 in.
 adjacente. Side 3 in.
 Côté 3 in.
 Minimum spacing above mounting surface. Bottom 4 in.
 L'espacement minimum au-dessus de la surface de montage. Bas 4 in.
 Suitable for installation on combustible floors.
 Convient à l'installation sur un plancher combustible.
 ANS Z83.11 • CSA 1.8-2007 Food Service Equipment
 SIMPSONVILLE, SC, USA
 DATE OF MANUFACTURE
 DATE DE FABRICATION
 12345678
 ETL US ETL
 N0656 -1

Intended for other than household use.
 Non destiné à l'usage domestique.
 For installation under ventilation hood only.
 Installer en dessous d'une hotte de ventilation seulement.
⚠ WARNING
 Improper installation, adjustment, alteration, service or maintenance can cause property damage, injury or death. Read the installation, operating and main-tenance instructions thoroughly before installing or servicing this equipment.
L'AVERTISSEMENT
 L'installation, le réglage, la modification, la réparation ou l'entretien incorrect de cet appareil peut causer des dommages matériels, des blessures ou la mort. Lire attentivement les instructions d'installation, de fonctionnement et d'entretien avant de procéder à son installation ou entretien.
 N0656 -2

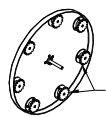
NORMAL OPERATION -
 1.) Turn main POWER switch on.
 2.) Touch controller screen to activate.
 3.) Select desired cook recipe.
 4.) Touch Cook or Preheat to start oven.
TO CANCEL COOK PROGRAM -
 1.) Touch [X] on upper right of controller screen and hold for 3 seconds.
NORMAL SHUT DOWN -
 1.) Cancel any activate cook program.
 2.) Wait 30 seconds for fans to stop.
 3.) Turn POWER switch off.
AFTER POWER or GAS OUTAGE -
 the oven will shut of automatically.
 To restart the oven, turn the POWER switch off and wait 5 minutes.
 Then follow NORMAL OPERATION procedures above.
Lubrificate rotor gears with BKI L0200
 Lubricant each day after cleaning. Failure to clean and lubricate the gears can damage the drive motor or warp the gear assembly.

 LUBRICATE HERE
 LUBRIFIEZ ICI
DO NOT use caustic cleaners when cleaning this unit.
NE PAS utiliser de nettoyeurs caustiques pour nettoyer cette unité.
 N0657

FONCTIONNEMENT NORMAL -
 1.) Allumez INTERRUPTEUR principal.
 2.) Ecran tactile de commande pour activer.
 3.) Sélectionner le programme de cuisson désiré.
 4.) Toucher Cook ou Preheat pour commencer four.
D'ANNULER LE PROGRAMME de CUISSON -
 1.) Toucher [X] sur le contrôle et pendant 3 secondes.
ARRÊT NORMAL -
 1.) Annuler le programme de cuisson actif.
 2.) Attendre 30 secondes pour les fans d'arrêter.
 3.) Couper le courant interrupteur.
APRÈS MISE SOUS TENSION ou de GAZ PANNE -
 le four automatically arrêter.
 Redémarrer le four, Couper le courant interrupteur et attendre 5 minutes.
 Puis suivre **FONCTIONNEMENT NORMAL** procédure ci-dessus.
Lubrifier les engrenages du rotor avec BKI L0200 lubrifiant chaque jour après le nettoyage. Défaut de nettoyer et lubrifier les engrenages peut endommager le moteur d'entraînement ou déformer l'engrenage.

⚠ NOTICE
 When this appliance is installed with casters, it must be installed with the casters supplied, a connector complying with either ANSI Z21.69 • CSA 6.16 and a quick-disconnect device complying with ANSI Z21.41 • CSA 6.9. It must also be installed with restraining means to guard against transmission of strain to the connector, as specified in the appliance manufacturer's instructions.
⚠ AVIS
 Les appareils sur roulettes doivent être pourvus des roulettes fournies, d'un tuyau de raccordement conforme à la norme ANSI Z21.69 ou CAN/CGA-6.16 et d'un raccord à débranchement rapide satisfaisant les exigences de la norme ANSI Z21.41 ou CAN1-6.9. Ils doivent aussi être munis d'un dispositif de retenue pour empêcher toute transmission de tension au tuyau de raccordement conformément aux instructions du fabricant.

FRONT of OVEN

BACK of OVEN

Health and Sanitation Practices

BKI Rotisserie Ovens are manufactured to comply with health regulations and are tested and certified to NSF and FSA standards. You must operate the equipment properly, using only quality products and use meat thermometers to insure meats are thoroughly cooked.

Food Handling

- Wash hands thoroughly in warm, soapy water after handling raw poultry or meats.
- Clean and sanitize all utensils and surfaces that have been in contact with raw products. Clean and sanitize the meat forks or baskets between cooking.
- **Never** place cooked meats on the same surfaces used to prepare raw meats, unless the area has been thoroughly cleaned and sanitized.

Storage of Raw Meats

- Designate an area or shelf strictly for the storage of all raw meats to be used in the rotisserie.
- Raw product must always be stored at temperatures below 38° F. (3° C.).
- **Never** store or mix raw foods above cooked foods, as this is a health hazard. The drippings from raw foods contaminate cooked or processed foods.
- All chicken and chicken parts to be stored overnight must be thoroughly iced down and refrigerated.

Coding Cooked Foods

All products cooked during the day should be sold the same day.

NOTE: It is not the intent of the rotisserie program to have unsold merchandise at the end of the cooking day. Follow your company's procedures for the handling of any leftover product.

Storage of Prepared Foods

- Cold foods should be kept at or below 38° F. (3° C.).
- Hot foods must be maintained to meet local health codes, usually a minimum 145° F. (63° C.).

Operation





Controls and Indicators

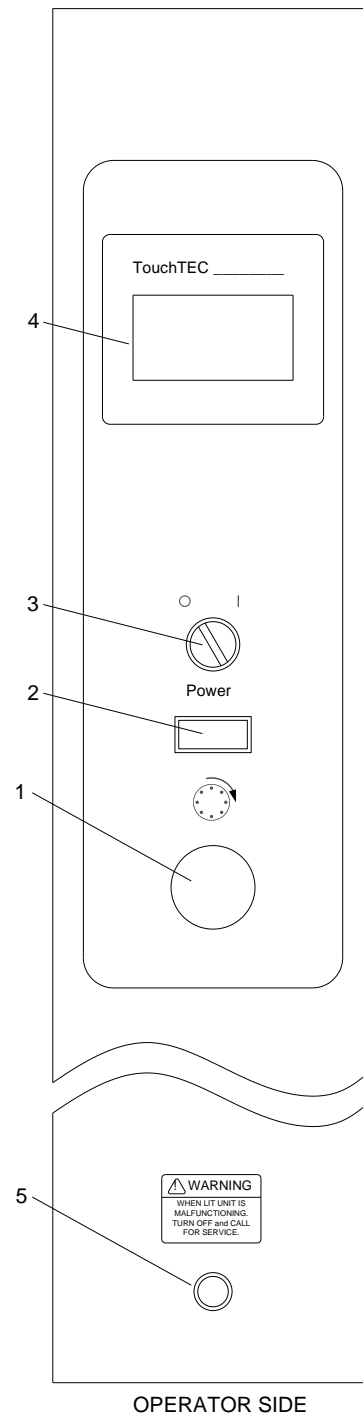

Hardware Controls

Item #	Description	Function
1	Rotor Switch	Depressing the switch allows the operator to “jog” the rotor position when the door is open. Releasing the switch stops the rotor.
2	Main Power Isolator Light	This light illuminates to indicate that power is being applied to the oven from the Main Power Isolator (Circuit Breaker).
3	Main Power Switch	Turns power to the entire unit on or off. When placed in the on position, the Touchscreen controller is powered, lights illuminate and the rotor motor engages (if both doors are closed). When placed in the off position, power is removed from the entire unit.
4	Analog Touchscreen Controller	Used for operation and programming of the oven. A built-in beeper is used to indicate touchscreen presses and other oven functions. It has 15 programmable cooking recipes.
5	Cooling Fan Indicator Light	This light illuminates to indicate there is a malfunction of the cooling fan in the control compartment. Call a qualified BKI service technician to repair the oven. The oven can still be operated with when this light is illuminated. However, operating the oven for an extended period of time may result in oven failure and damage to additional components.

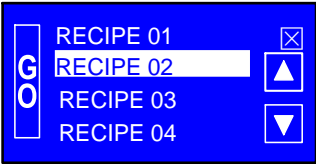
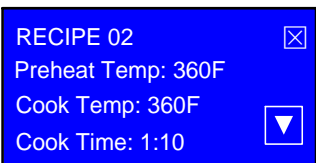
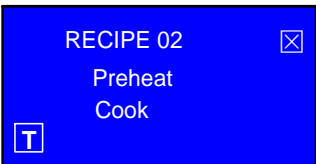



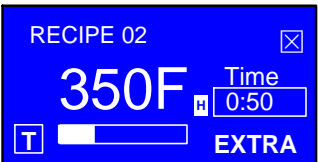
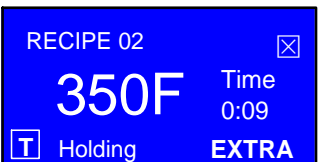



Software Controls – Operation Screens

Screen Name	Screen	Description
Startup		Appears when the Main Power Switch is placed in the on position.
Controller Off		Appears after the Startup screen displays. This screen indicates that the controller is turned off. Touching anywhere on the screen will turn the controller on and display the Recipe Selection screen.
Recipe Selection		Displays a list of available recipes. The up and down arrow buttons move the highlight box from one recipe to the next. Once the desired recipe is highlighted the user touches the GO button to start the cook cycle. Touching the X button for 3 seconds turns the controller off. Touching any recipe will show the settings for that recipe.
Recipe Settings		Displays Preheat Temperature, Cook Temperature, Cook Time, Hold Temperature and Cook To settings for a selected recipe. Touching the up and down arrow buttons scroll the screen to view more settings. Touching the X button momentarily returns you to the previous screen.
Preheat/Cook Selection		Displays once the user highlights a recipe and touches the GO button if the recipe has a preheat temperature programmed. The user selects where to start the cooking cycle by touching Preheat or Cook . Touching Preheat displays the Preheat screen. Touching Cook displays the Ready To Cook screen. If the Preheat temperature is set to OFF the controller goes directly to the Ready To Cook screen. The T button can be used to display the current oven temperature. Touching the T button displays the temperature, then automatically returns to the previous screen in 2 seconds. Touching the X button momentarily returns you to the previous screen.
Preheat		Displays once the user touches the Preheat option from the Preheat/Cook Selection screen. The Preheat cycle heats the cooking cavity up to the pre-defined preheat temperature. Once this temperature is reached the unit automatically switches to the Ready To Cook mode. A small highlighted letter H will appear to the right of the temperature display to indicate that the controller has energized the heating elements. The absence of the letter H indicates that the controller has de-energized the heating elements as the oven temperature has reached the set temperature limit. The T button works as described for the Preheat/Cook Selection screen. Touching the X button for 3 seconds returns you to the Recipe Selection screen.

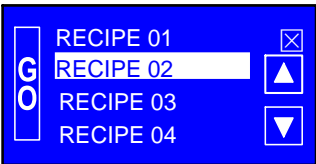
Screen Name	Screen	Description
Ready to Cook		<p>Displays once the user touches the Cook option from the Preheat/Cook selection screen or once the preheat cycle is finished or directly from the Recipe Selection screen if no preheat temperature was programmed. When the temperature is within 5° of the cook temperature the controller will emit three 2 second beeps indicating that the product can be loaded. The user places the product to be cooked into the cooking cavity and touches the COOK button to start the cooking process. If the door is opened and/or the temperature drops below 25° below the preheat temperature, the screen will flash and beep every 30 seconds until the COOK button is touched. The highlighted letter H works as described for the Preheat screen. The T button works as described for the Preheat/Cook Selection screen. Touching the X button for 3 seconds returns you to the Recipe Selection screen.</p>
Cooking		<p>Displays once the COOK button is touched from the Ready To Cook screen. This screen shows the cooking temperature, the time remaining in the cook cycle, and the elapsed time shown with the progress bar at the bottom of the screen. Hold the X button for 2 seconds to stop the cook in progress. The EXTRA button can be used to add more cook time to the cycle. The cook cycle ends when the cook time elapses. This is indicated by three 2 second beeps. If a hold temperature was programmed then the Hold screen is displayed. If no hold temperature was programmed then the screen will flash and beep until touched. The highlighted letter H works as described for the Preheat screen. The T button works as described for the Preheat/Cook Selection screen. Touching the X button for 3 seconds returns you to the Preheat/Cook Selection screen.</p>
Hold		<p>Displays once the cook cycle is complete if a hold temperature was programmed. This screen displays the hold temperature (or nothing if set to OFF), and the elapsed time in the hold mode. The EXTRA button is available here so the product can be cooked for more time if required. The highlighted letter H works as described for the Preheat screen. The T button works as described for the Preheat/Cook Selection screen. Touching the X button for 3 seconds returns you to the Recipe Selection screen.</p>
Extra Cook		<p>Appears when the EXTRA button is touched from the Cooking or Hold screens. Use the up and down arrow buttons to set the amount of additional cook or hold time in 5 minute increments. Touch the GO button to add the additional time you set. Touch the X button to return to the previous screen without adding any extra cook or hold time.</p>

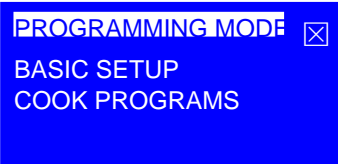
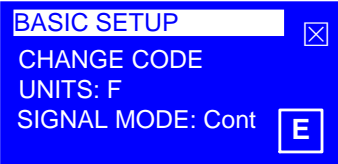
Software Controls – Programming Screens

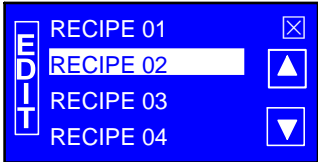
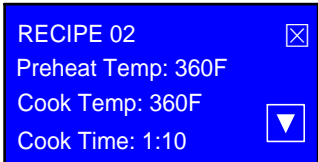
Screen Name	Screen	Description
Startup		Appears when the Main Power Switch is placed in the on position.
Controller Off		Appears after the Startup screen displays. Indicates that the controller is turned off. Touching anywhere on the screen will turn the controller on and display the Recipe Selection screen.
Recipe Selection		Appears once the Controller Off screen is touched. Touch any recipe for 3 seconds to enter the programming mode. Touch the X button for 3 seconds to turn the controller off.
Program Security		Appears upon entering the programming mode and is used to enter a 4 digit passcode. When the controller is first powered, 0000 is used to access the programming mode. Upon subsequent access, if you don't want to use a special passcode but want to leave it 0000 just press the GO button. If you do want to use a special passcode, configure one using the Basic Setup screen. Use the left and right arrow buttons to move the cursor under the digit to be changed. The up and down arrow buttons increase or decrease the digit as desired. Touch the GO button to submit the security passcode. If the passcode is valid the Programming mode Selection screen will appear. If the passcode is invalid the Program Security screen will reappear showing the passcode you entered. Touch the X button to return to the previous screen.
Program Mode Selection		Appears once a valid passcode is entered from the Security screen. Touch the BASIC SETUP option to change basic controller parameters. Touch the COOK PROGRAMS option to change cook parameters for a specific recipe. Touch the X button to return to the Recipe Selection screen.
Basic Setup		Appears when the BASIC SETUP option is touched from the Programming Mode Selection screen. Use this screen to configure the controller to display temperature in Fahrenheit or Centigrade, to use short or long beeps at the end of a cook cycle and to modify the four digit passcode. The E in the bottom right corner toggles between English and Spanish on the display. Touch the X button to return to the previous screen.

Screen Name	Screen	Description
Recipe Edit Selection		<p>Appears when the COOK PROGRAMS option is touched from the Programming Mode Selection screen. This screen is used to select the recipe you want to edit. Use the up and down arrow buttons to highlight the recipe then touch the EDIT button. Touch the X button to return to the previous screen.</p>
Recipe Parameter Selection		<p>Appears when a recipe is selected and the EDIT button is touched from the Recipe Edit Selection screen. This screen is used to select a specific recipe parameter to edit. Use the up and down arrow buttons to scroll through the list of parameters and touch the parameter you want to change. Touch the X button to return to the previous screen.</p>
Recipe Parameter Edit		<p>Appears when a recipe parameter is touched from the Recipe Parameter Selection screen. This screen is used to edit a specific recipe parameter. The editable parameters are: Recipe name, Preheat Temp, Cook Temp, Cook Time and Hold Temp. The left and right arrow buttons are used to move the cursor under the character to be changed. The up and down arrow buttons changes the character as desired. The Preheat Temp and Hold Temp parameters can be turned off by scrolling the temperature below 150°. Touch the SAVE button to save the changed parameter. Touch the X button to abort all changes and return to the previous screen.</p>

Programming the Controller Using the Touchscreen Interface

Use the procedures below to edit a separate recipe or to change the basic controller configuration.

Edit a Recipe

1. Turn on the Power Switch. The Startup screen will briefly appear then the Controller Off screen will display.
2. Touch anywhere on the touchscreen. The Recipe Selection screen will appear displaying a list of recipes.
3. Touch any recipe for 3 seconds. The Security screen will appear.
4. Use the up/down and left/right arrow buttons to enter the passcode and touch the **GO** button. The Program Mode Selection screen will appear if a valid passcode is entered.
5. Touch the **COOK PROGRAMS** option. A Recipe Edit Selection screen will appear.
6. Highlight the recipe you want to edit using the up/down arrow buttons then touch the **EDIT** button. The Parameter Selection screen will appear.
7. Use the up/down arrow buttons to view the recipe parameters and touch the parameter you want to edit. The Parameter Edit screen will appear.
8. Change the parameter value using the left/right and up/down arrow buttons then touch the **SAVE** button to save your changes. You will return to the Parameter Selection screen.
9. Repeat the process to change any other parameters.
10. Touch the **X** button as necessary to return to the Recipe Selection screen.

Edit the Basic Setup

1. Turn on the Power Switch. The Startup screen will briefly appear then the Controller Off screen will display.
2. Touch anywhere on the touchscreen. The Recipe Selection screen will appear displaying a list of recipes.
3. Touch any recipe for 3 seconds. The Security screen will appear.
4. Use the up/down and left/right arrow buttons to enter the passcode and touch the **GO** button. The Program Mode Selection screen will appear if a valid passcode is entered.
5. Touch the **BASIC SETUP** option. A Basic Setup Selection screen will appear.
6. Touch the parameter that needs to be changed. A Basic Setup Parameter Edit screen appears.
7. Change the parameter value using the left/right and up/down arrow buttons then touch the **SAVE** button to save your changes. You will return to the Basic Setup Selection screen.
8. Repeat the process to change any other parameters.
9. Touch the **X** button as necessary to return to the Recipe Selection screen.

Operation with the Controller

Use the procedures below to view a separate recipe or to activate a cook cycle using a one of the preprogrammed recipes.

Viewing Recipes

1. Turn on the Power Switch. The Startup screen will briefly appear then the Controller Off screen will display.
2. Touch anywhere on the touchscreen. The Recipe Selection screen will appear displaying a list of recipes.
3. Use the up/down arrow buttons to highlight the recipe you wish to view then touch it. A Recipe Settings screen will appear.
4. Use the up/down arrow buttons to view any settings for the recipe selected.
5. Touch the **X** button momentarily to return to the previous screen.

Cooking

1. Turn on the Power Switch. The Startup screen will briefly appear then the Controller Off screen will display.
2. Touch anywhere on the touchscreen. The Recipe Selection screen will appear displaying a list of recipes.
3. Use the up/down arrow buttons to highlight the recipe you wish to use then touch the **GO** button. If a preheat temperature was programmed then the Preheat/Cook Selection screen will appear. If no preheat temperature was programmed then the controller enters the Ready To Cook mode displaying the Ready To Cook screen.
 - If the Preheat/Cook Selection screen appears, do either of the following:
 - Touch the **Preheat** option to enter the Preheat mode. The controller will display the Preheat screen. Once the preheat temperature is reached the controller enters the Ready To Cook mode.
 - Touch the **Cook** option to enter the Ready to Cook mode.

Once the temperature is within 5° of the cook temperature in the Ready To Cook mode the controller will emit three 2 second beeps indicating that the oven can be loaded with product.
4. Load the product into the oven. Use the Rotor Switch on the front panel to operate the rotors during loading.
5. Close the door.
6. Touch the **COOK** button. The controller now enters the cook mode and displays the cooking temperature, time remaining in the cook cycle and the elapsed time. If necessary, use the **EXTRA** button to add more cook time to the cycle. At the end of a cook cycle the controller will emit three 2 second beeps and enter the Hold mode and display the Hold screen if a Hold temperature was programmed. If a Hold temperature was not programmed the screen will flash and beep until touched.
7. Open the oven door and check the product for proper internal temperature. If necessary, use the **EXTRA** button to add more cook time.
8. Unload the product if it is done.

Operation After a Gas or Power Outage

The oven will shut off automatically if the gas supply is interrupted or the power goes out. If either of these conditions occur you should perform the following procedure:



For your safety, if there is an interruption in the gas or power supply, make sure to wait for at least five minutes before restarting your oven. This allows time for any unburned gas to dissipate. (LP gas may take longer than five minutes.) If you smell gas, do not start your oven.

1. Place the Main Power Switch to the "OFF" position.
2. Wait at least 5 minutes to allow gas that may have accumulated in the burner compartment to escape.
3. Follow normal operating procedures once the power or gas is restored.

Normal Shutoff

1. Stop cooking and remove all food products from the oven.
2. Turn the Main Power Switch to the "OFF" position.
3. Allow oven cavity to cool before cleaning.

Installing Rotor System

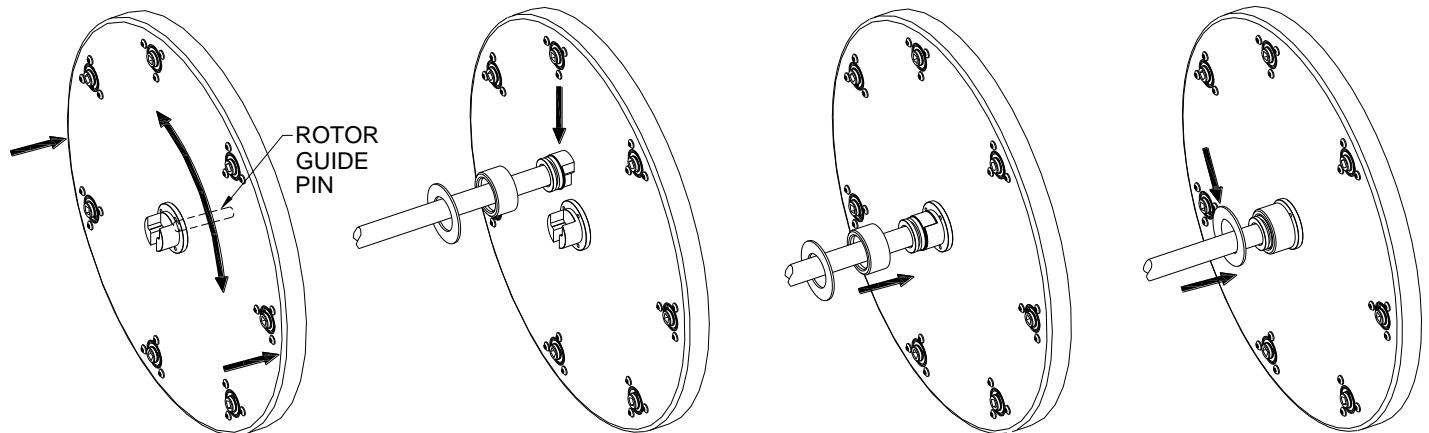

STEP 1
Install the Rotor Disks by first inserting the guide pin into the shaft center hole. The Rotor Disk with gears goes on the control side of the oven. It will be necessary to rotate this Rotor Disk while pushing in to engage the gears and the drive hub. When properly installed there will be approximately ¼" [6 mm] space between the Rotor Disk and cavity side.

STEP 2
Rotate both Rotor Disks so that the wide side of the T-slot in the hubs is facing up as shown. Hold the Rotor Shaft with wide side of the T-shaped tabs in end hubs facing up. Slide the T-shaped tabs in the Rotor Shaft ends into the corresponding slots in the hubs.

STEP 3
Slide the Retaining Cups on each end of the Rotor Shaft completely onto the Rotor Hubs. The grooves in the Rotor Shaft end hubs must be visible.

STEP 4
Slide the Retaining Washers onto the Rotor Hubs and seat them in the grooves in the Rotor Shaft end hubs.

Preparing and Loading Chickens

Trussing Chickens

It is recommended that whole chickens be trussed before cooking. Trussing holds the wings and legs of the chicken tightly against the body. This improves the visual appeal of the chickens while they are cooking. In addition trussing keeps the chicken moist by retaining more of the natural juices and helps prevent the wing tips from burning.

Using 6 ½" – 7" elastic ties, follow these simple steps to truss the chickens.



1. Fold wing tips back under the chicken.



2. With the back of the chicken up slip the tie under the wings and pull back.



3. Pull and twist the tie over the back of the chicken to form an "X". Make sure wing tips are under tie.



4. Turn the chicken over and pull the tie over the ends of the legs.

V-Spits

Up to four (4) whole chickens can be placed on a DRGV-7 v-spit. Insert the tapered (square pin) end of the v-spit under the legs and through the cavity of the trussed chicken as shown below. Orient the spit with the “V” toward the breast side of the chicken. The legs and thighs of the chicken should be on the same side of the v-spit as the breast.



Make sure the chickens are evenly spaced on the v-spit. Do not place more than four chickens on a v-spit. Chickens that are pushed tightly together on the v-spit will not brown properly during cooking leaving “blonde” areas where the two chickens were touching.

The DRGV-7 will hold up to 7 v-spits. When loading less than 7 spits, space the spits as evenly as possible on the rotors. Balancing the load on the rotors will extend the life of the rotor drive system. When loading only 2 or 3 spits **DO NOT** place them in adjacent mounting locations on the rotors.

Load the first v-spit on the rotors as described below. Use the rotor jog button to advance the rotors while loading additional v-spits.

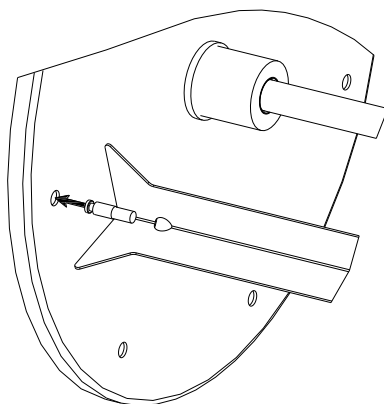

STEP 1

Orient the V-spit with the round pin to the left. Insert the round pin completely into the hole in the passive (left) side rotor.

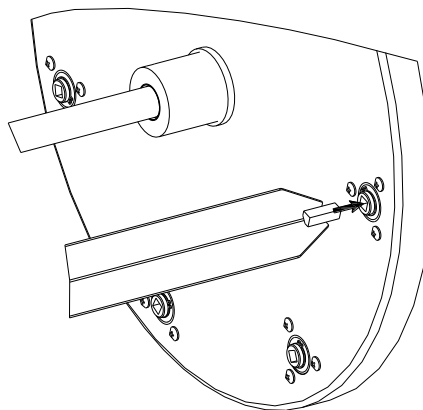

STEP 2

Rotate the V-spit so that the flats of the square pin align with the square opening in the drive (right) rotor. Insert the square pin completely into the square opening in the rotor.

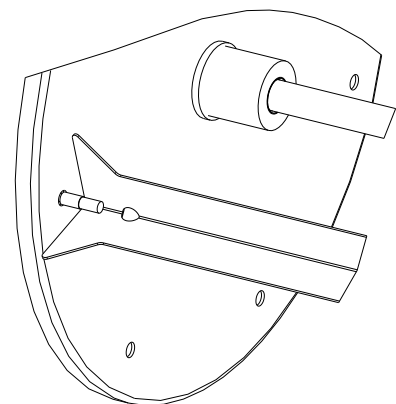

STEP 3

Verify that rotor disk slips into the slot in the round pin on the left end of the V-spit.

Baskets

The optional tiered clamping baskets can be used to cook a wide variety meat portions and proteins. By using the intermediate trays two layers of smaller portions can be cooked in a single basket. Note that these baskets will not produce an even browning on the exterior of the cooked products.

Place the portions to be cooked in the Lower Tray of the baskets. The portions should be evenly distributed in the Lower Tray with some space between each portion for adequate heat circulation.

Slide the Upper Tray over the vertical pins in the Lower Tray. Push the Upper Tray down onto the portions to be cooked firmly enough that the portions do not move in the basket. Tighten the thumb screws securely on each end with the thumb screw wrench. For larger portions, the Intermediate Tray can be used in place of the Upper Tray.

To cook two layers of portions in the basket, load the first layer in the Lower Tray and secure this layer with the Intermediate Tray as described above. In similar fashion place the second layer of portions in the Intermediate Tray and secure this layer with the Upper Tray.

Load the baskets onto the ovens rotor system as described above for the V-spits.

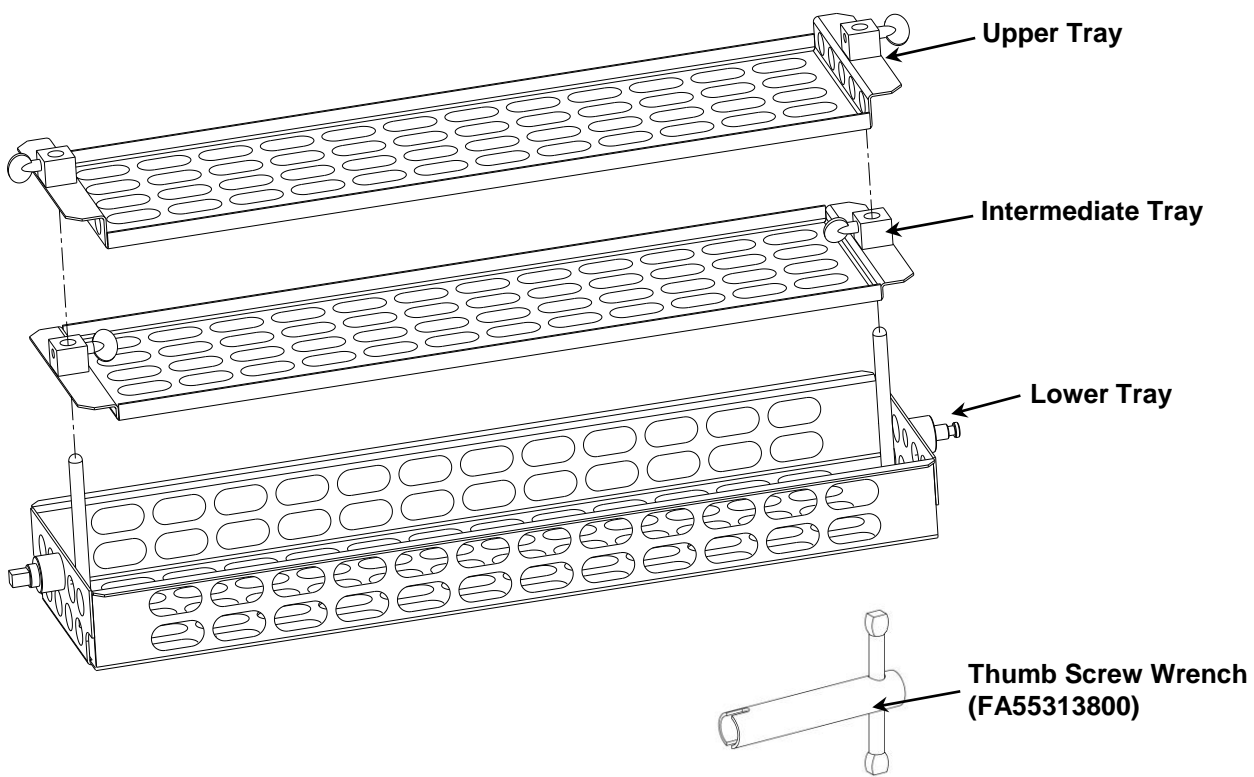

Installation

WARNING

Serious injury, equipment damage or death could result if attempting to install this oven yourself. Ensure that an authorized **BKI** service agent installs the oven.

Unpacking and Handling

It is the owners' responsibility to file all freight claims with the delivering truck line. Inspect all cartons and crates for damage as soon as they arrive. If damage to cartons or crates is found, or if a shortage is found, note this on the bill of lading (all copies) prior to signing.

If damage is found when the equipment is opened, immediately call the delivering truck line and follow up the call with a written report indicating concealed damage to your shipment. Ask for an immediate inspection of your concealed damage item. Packaging material **MUST** be retained to show the inspector from the truck line.

Remove all packing from the interior and exterior of the oven.

Location and Clearance

Install your oven in a well-ventilated area. This will ensure that the gas burns properly and will help prevent any fires.

The oven must be mounted on a level surface capable of supporting the fully loaded oven. Refer to Chart 1 for oven weight.

Adequate clearance must be provided around the oven for safety, proper operation and ventilation. Refer to Chart 1 for required minimum clearances. Note that these are minimum clearances. If the oven is to be permanently mounted near other immovable objects additional clearance must be provided for connection and service of the oven on both sides.

All ventilation slots must be kept free from obstruction. The area around oven must be kept free and clear from combustibles.

Specific Instructions

WARNING

The oven must be installed under a ventilation hood. If the oven is not properly ventilated, carbon monoxide can be released around the oven. Asphyxiation or suffocation can occur if gas is not ventilated properly.

NOTICE

Installation of this appliance must conform with local codes, or in the absence of local codes, with the *National Fuel Gas Code ANSI Z223.11/NFPA 54* or *Natural Gas and Propane Code CSA B149.1* as applicable.

- This appliance and its individual shutoff valve must be disconnected from the gas supply piping system during any pressure testing of that system at test pressures in excess of ½ psi (3.5kPa).
- The appliance must be isolated from the gas supply piping system by closing its individual shutoff valve during any pressure testing of the gas supply piping system at test pressures equal to or less than ½ psi (3.5kPa).

NOTICE

When installed, this appliance must be electrically grounded in accordance with local codes, or in the absence of local codes, the *National Electric Code ANSI/NFPA 70* or the *Canadian Electrical Code CSA C22.2*, as applicable.

A wiring diagram is located on the inside of the appliance's right side panel.

WARNING

This appliance is equipped with a 3-prong (grounding) plug for your protection against shock hazard and should be plugged directly into a properly grounded 3-prong receptacle. Do not cut or remove the grounding prong from the plug.

NOTICE

When this appliance is installed with casters, it must be installed with the casters supplied, a connector complying with either ANSI Z21.69 • CSA 6.16 and a quick-disconnect device complying with ANSI Z21.41 • CSA 6.9. It must also be installed with restraining means to guard against transmission of strain to the connector, such as BKI part number FT0279.

Chart 1. Location and Clearance

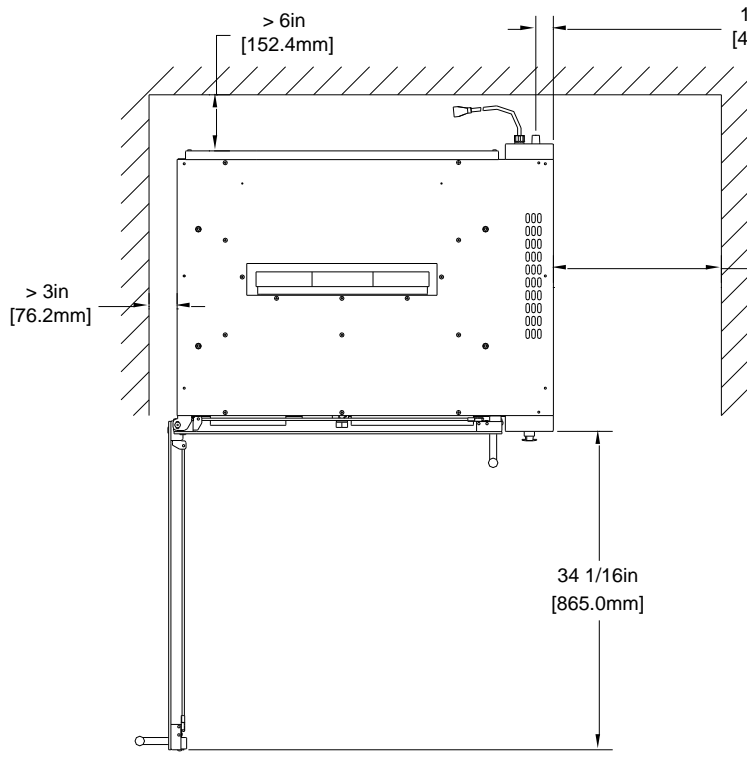

Counter Top and Stand

TECHNICAL SPECIFICATIONS:

- Net Weight: 450 lbs [204 kg]
- Floor Space: 13.2 sq ft [1.2 sq m]
- Voltage: 115V
- Phase: 1~
- Frequency: 60 Hz
- Amperage: 4.5A
- Electrical Power: 540W
- Electrical Plug: NEMA 5-15P
- Gas Power: 75,000 BTU Max.
- Gas Types: Natural & Propane
- Min. Gas Pressure: 5 inch W.C.
- Max. Gas Pressure: 14 inch W.C.
- Gas Inlet: 3/4" NPTM

FOR PROPER OPERATION
Use a minimum 3/4" pipe and
3/4" ID flexible gas connector
for gas supply connection.

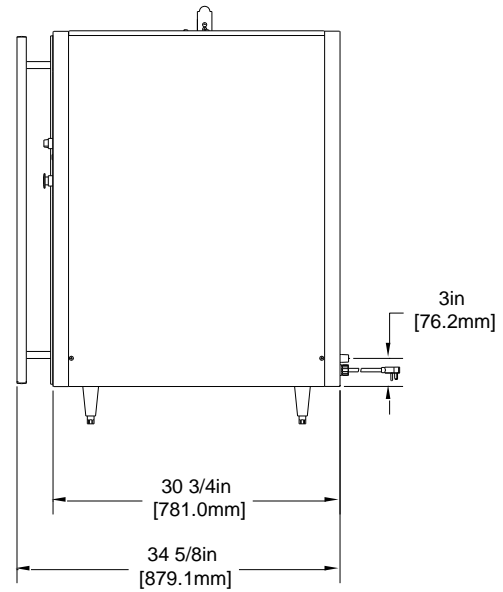
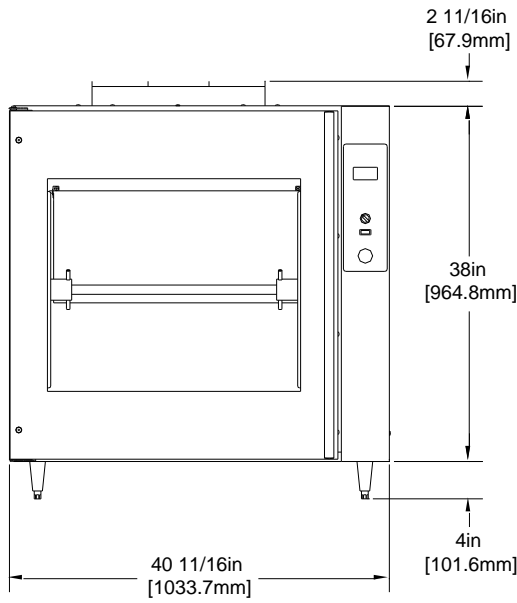

Model DRGV-7 Gas Rotisserie Oven

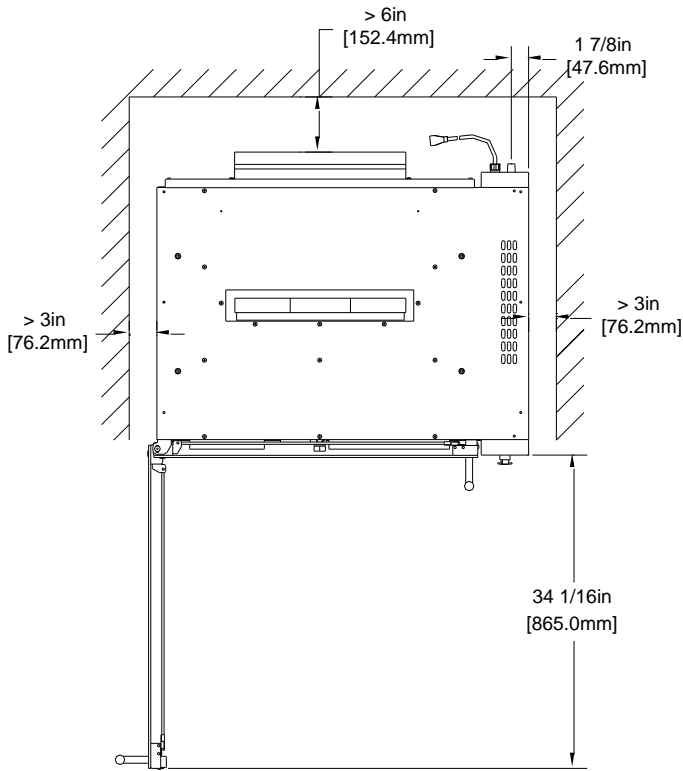

TECHNICAL SPECIFICATIONS:

- Net Weight: 900 lbs [408 kg]
- Floor Space: 13.9 sq ft [1.3 sq m]
- (2) Ovens Connect Independently
- Specifications for Single Oven
- Voltage: 115V
- Phase: 1~
- Frequency: 60 Hz
- Amperage: 4.5A
- Electrical Power: 540W
- Electrical Plug: NEMA 5-15P
- Gas Power: 75,000 BTU Max.
- Gas Types: Natural & Propane
- Min. Gas Pressure: 5 inch W.C.
- Max. Gas Pressure: 14 inch W.C.
- Gas Inlet: $\frac{3}{4}\text{"}\text{ NPTM}$

FOR PROPER OPERATION
 Use a minimum $\frac{3}{4}\text{"}\text{ pipe}$ and $\frac{3}{4}\text{"}\text{ ID flexible gas connector}$ for gas supply connection.

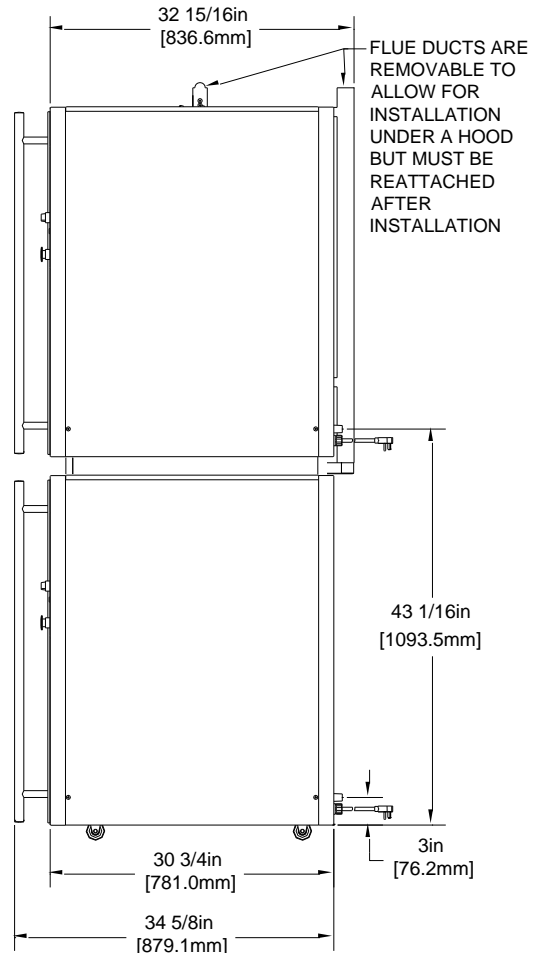
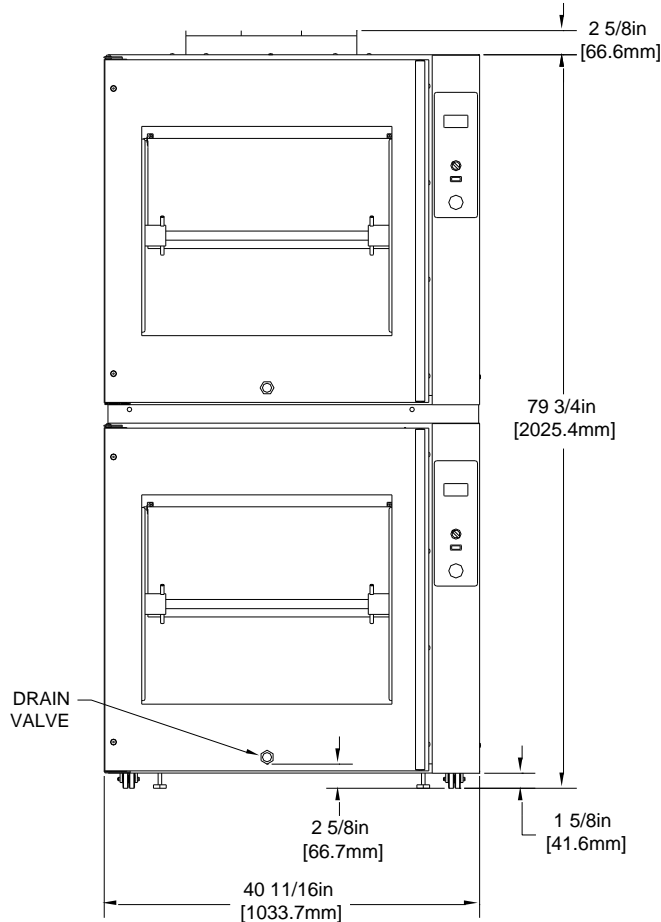

FLUE DUCTS ARE REMOVABLE TO ALLOW FOR INSTALLATION UNDER A HOOD BUT MUST BE REATTACHED AFTER INSTALLATION

Model DRGV-14 Gas Rotisserie Oven

Mounting

NOTICE

This appliance cannot be mounted directly on a counter top. Air must be able to circulate under the appliance. To prevent equipment damage the appliance must be mounted on legs, casters or a stand with an open appliance mounting surface.

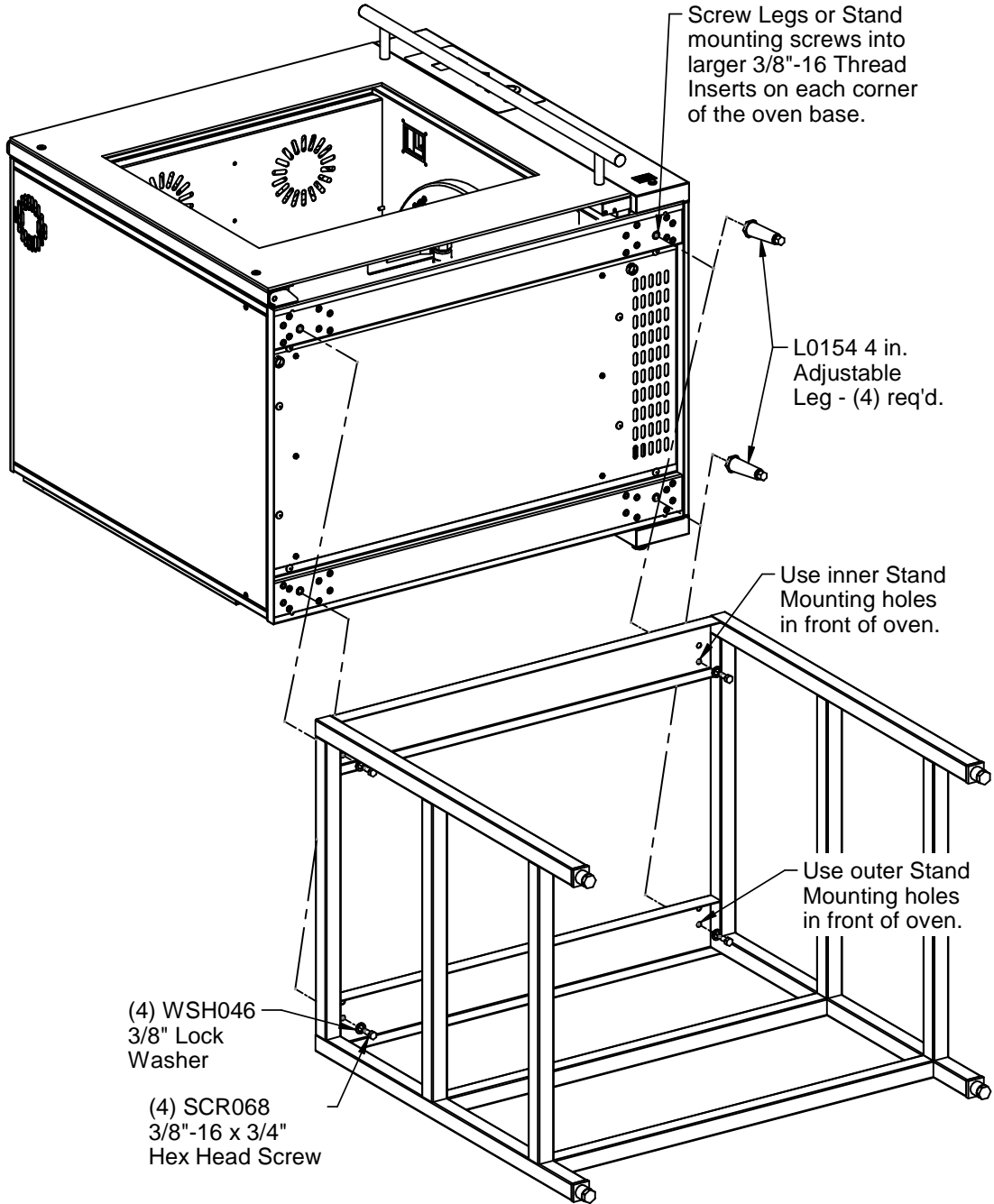

Stacking Ovens



Serious injury, equipment damage or death could result if attempting to install these ovens yourself. Special equipment is required to lift and stack two ovens. Ensure that an authorized **BKI** service agent installs the oven.

A DRGV-14 two cavity oven is shipped from the factory as two individual ovens along with the components required to assemble them into a single unit. The lower oven will have casters installed, the upper oven will not.

Prepare the top oven by attaching the mounting angle to the bottom as illustrated below.

Attach passive (hinge) side Mounting Angle to outer threaded inserts in base channels.

Attach drive (control) side Mounting Angle to inner threaded inserts in base channels.

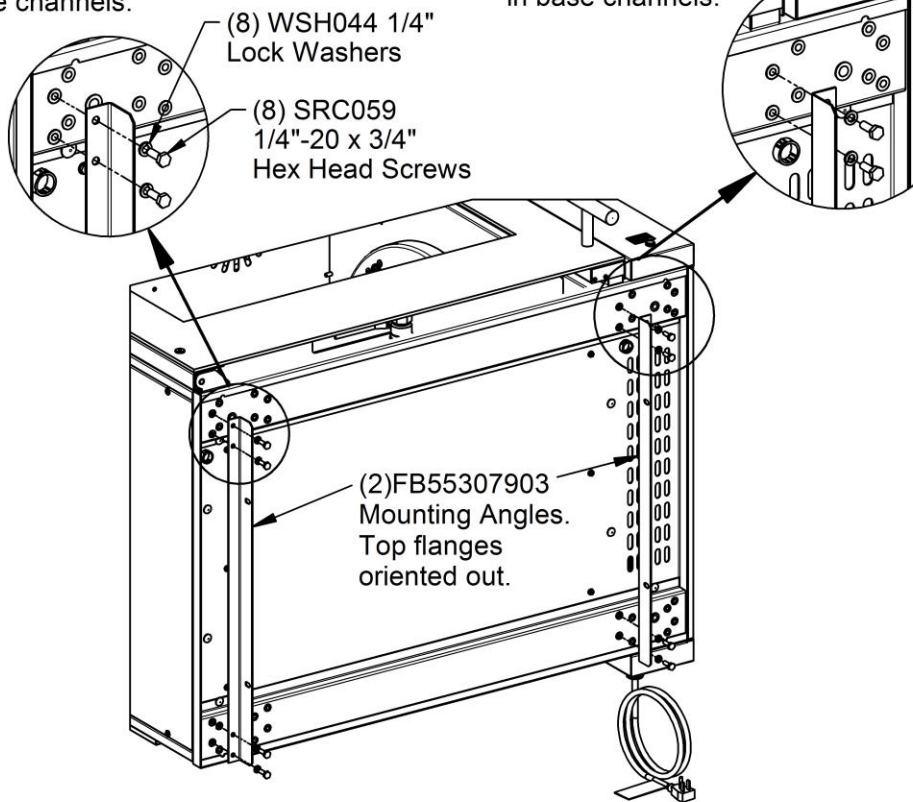

Oven with LH Hinge shown, Oven with RH Hinge opposite.

Prepare the lower oven by first removing the two side panels. Then attach the stacking channels, flue duct and baffle as detailed in the following illustrations.

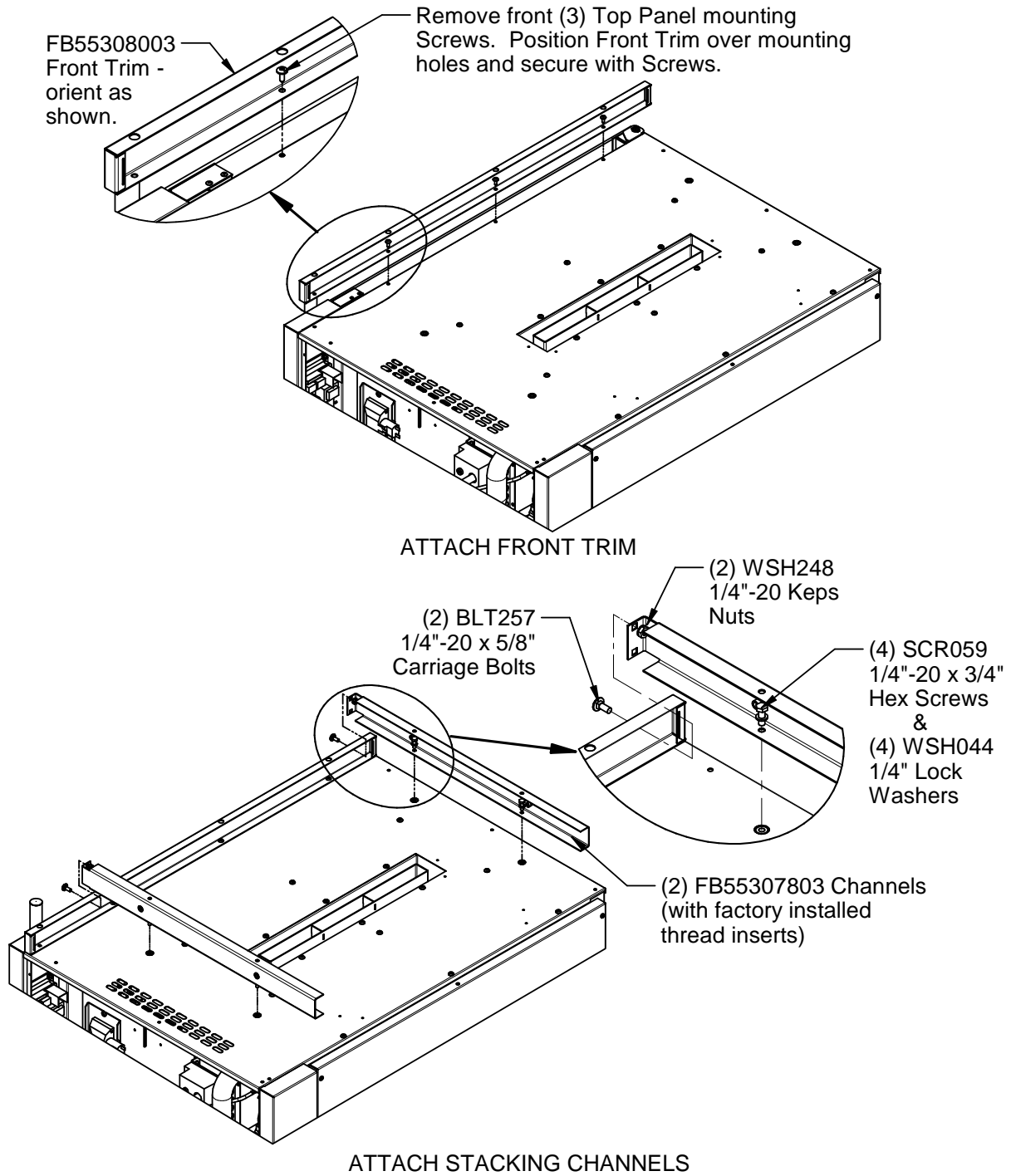

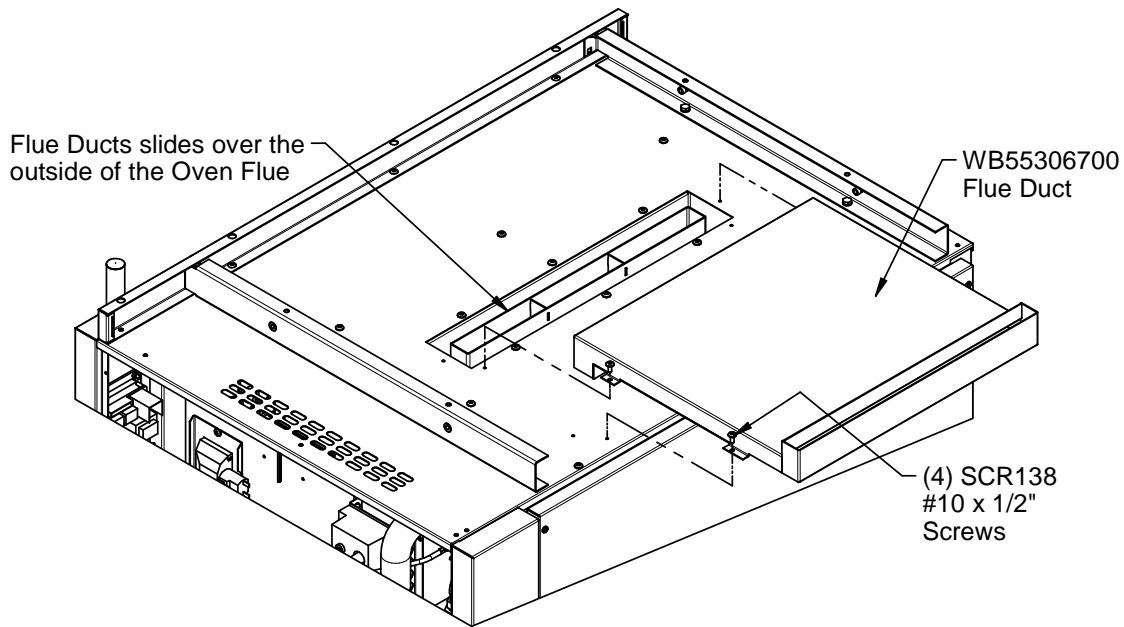

ATTACH FLUE DUCT

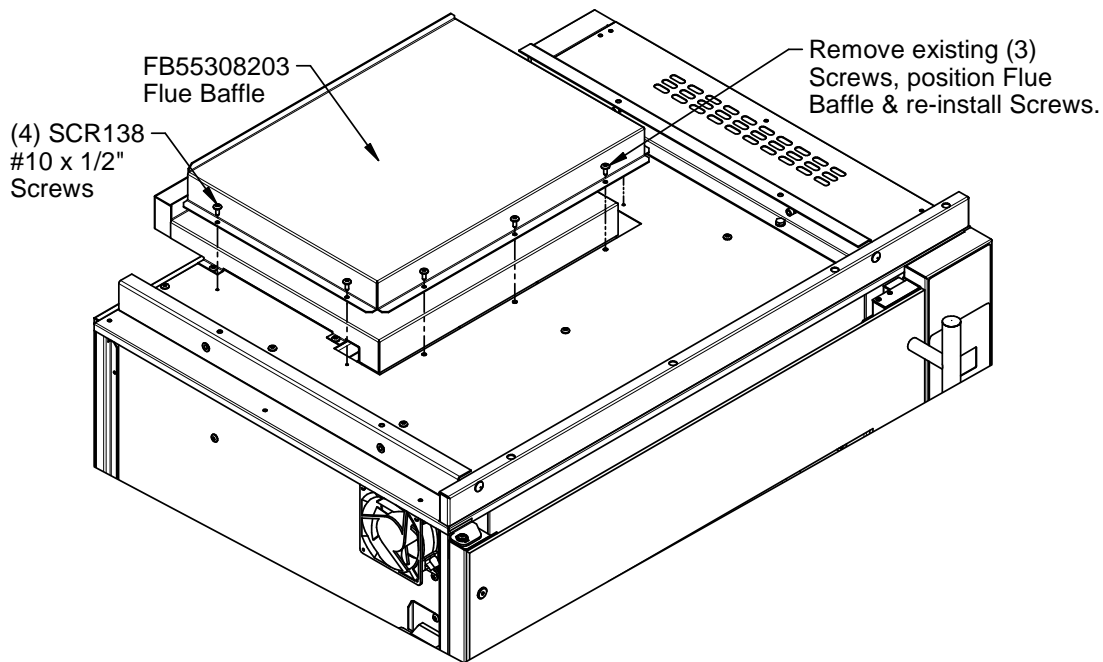

ATTACH FLUE BAFFLE

Lift the top oven and set it in place on the lower oven as shown in the following illustration. Ensure the lifting equipment has a rated capacity of at least 500 lb. [250 kg].

The angles on the bottom of the top oven slide over the outside of the channels attached to the top of the lower oven.

Secure the two ovens to each other with the fasteners noted on the illustration.

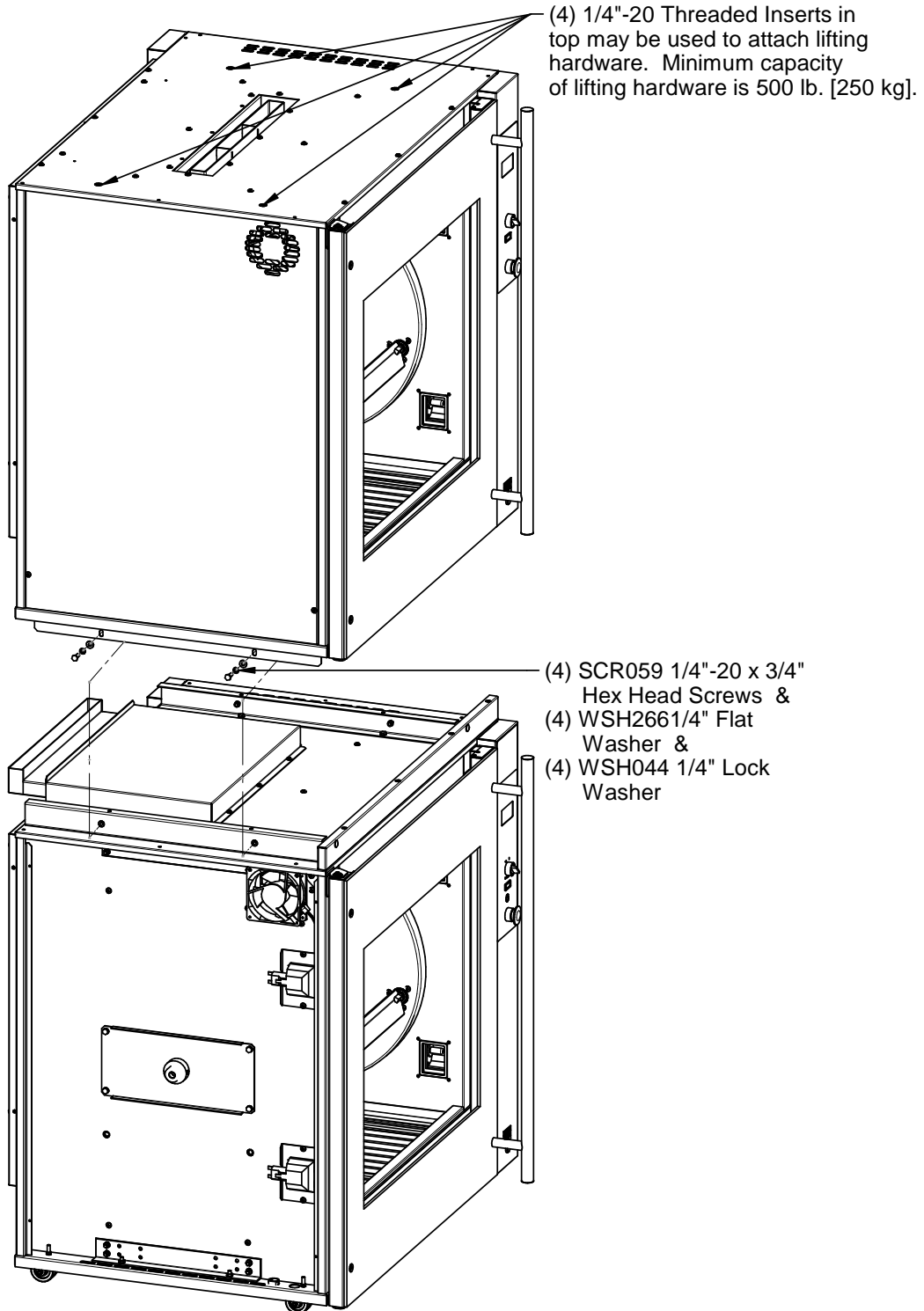

Attach Lower and Upper Oven Flue Chimneys and Side Trims as illustrated below.

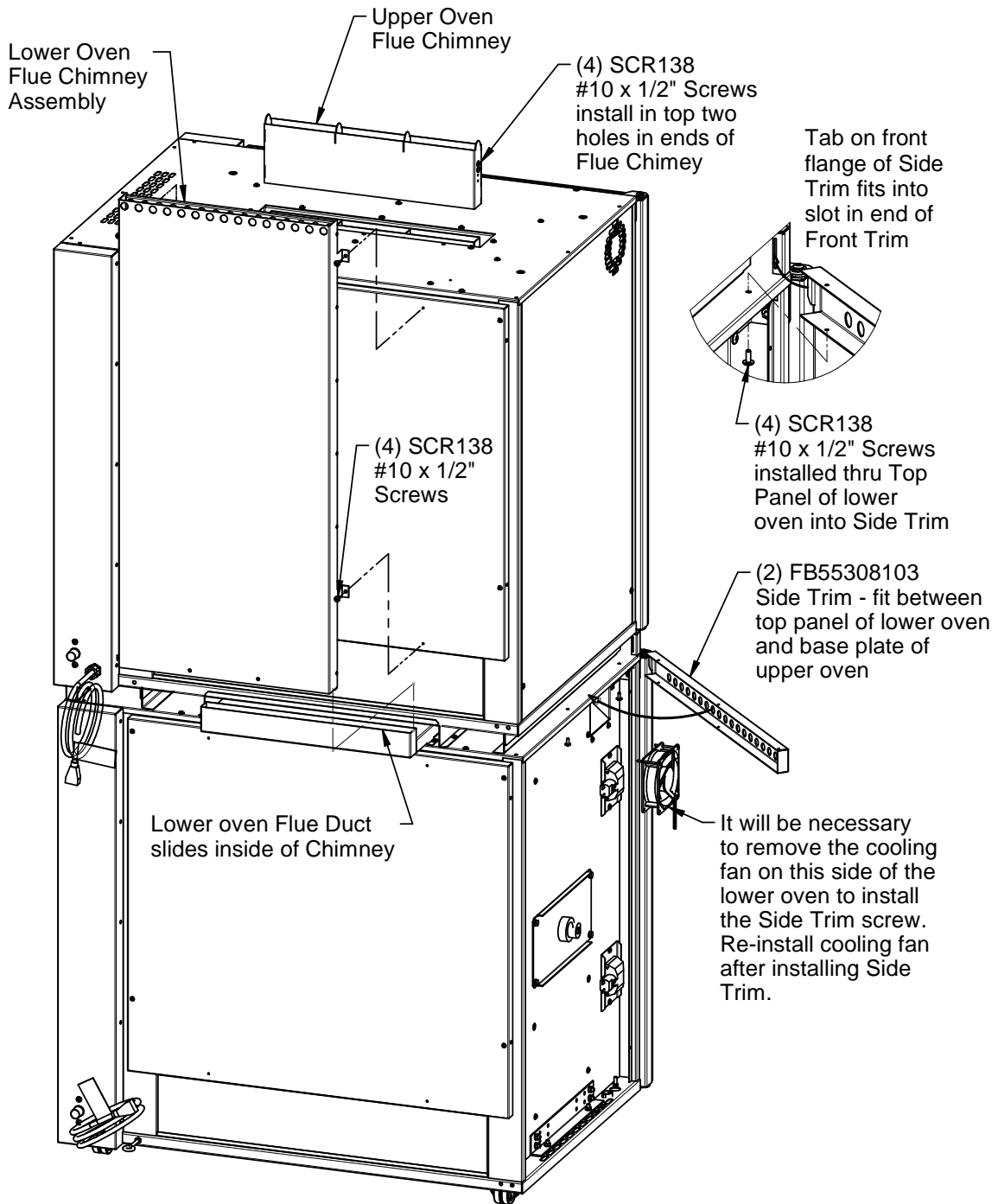

Locking Ovens in Place



For ovens equipped with casters, injury or equipment damage could result if the ovens are not locked in position to prevent movement during normal operation.

Locking casters are provided on ovens with 3" diameter and larger casters. To prevent movement of the ovens once they are in their installed position depress the caster locking lever on the side of the two front casters with your foot.

Low profile ovens with 2" diameter casters are provided with two legs in the front of the base of the lower oven. Once the ovens are moved to their installed position, lower these legs to firmly contact the floor, preventing movement of the ovens.

DRGV-14 LOWER OVEN with 2" CASTERS

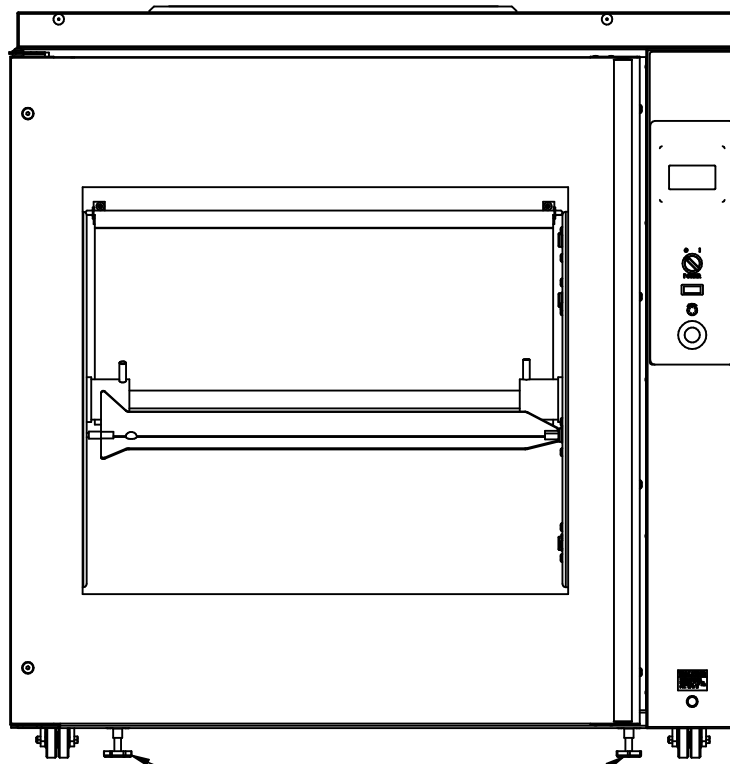

LEG LEVELERS TO BE LOWERED
TO CONTACT FLOOR TO PREVENT
MOVEMENT WHEN OVEN IN
OPERATING POSITION

Gas Supply Connection

NOTICE

Installation of this appliance must conform with local codes or in the absence of local codes with the *National Fuel Gas Code ANSI Z223.11/NFPA 54* or *Natural Gas and Propane Code CSA B149.1* as applicable.

The gas supply connection for the oven is located on the the oven as shown. A separate gas supply must be for each oven cavity for stacked ovens (DRGV-14).

A 3/4" NPT nipple is provided for the gas supply connection. For proper oven operation the gas supply and connector must have a minimum capacity of 80,000 Hr. If a flexible connector with quick disconnect device is a minimum 3/4" ID flexible connector and quick disconnect device must be used.

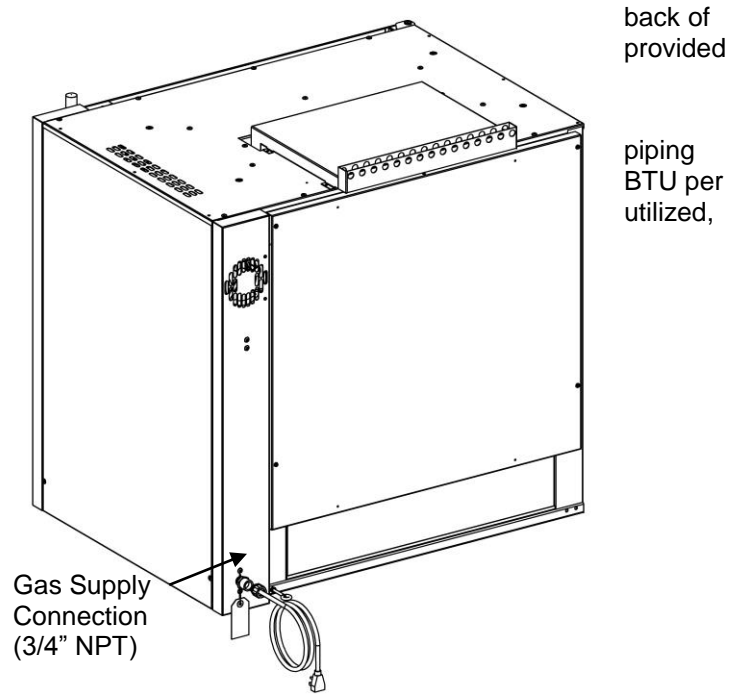

Gas Manifold Pressure Test

The gas manifold pressure is preset at the factory. Due to variations in gas supply pressures, the manifold pressure should be checked after installation of the oven.

Refer to the oven's rating plate for the required manifold pressure setting. Typically the manifold pressure will be 4 1/2 in W.C. for natural gas and 7 in W.C. for lp gas.

To check the manifold pressure connect a manometer to the *OUTLET PRESSURE TAP* (see diagram at right). Connect the oven's gas supply and electric cord, turn the oven on and start a cook program so that the oven burner lights. With the burner lit compare the manifold pressure on the manometer to the rated *manifold pressure*.

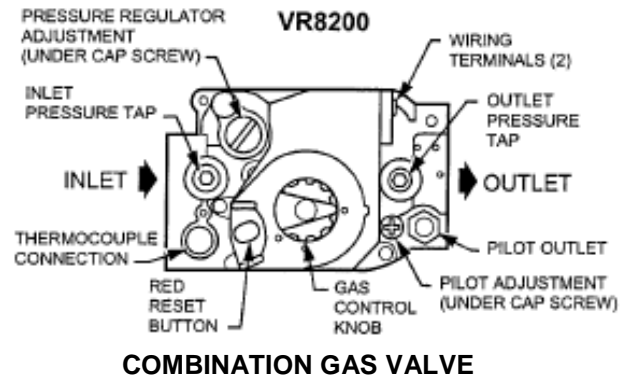

COMBINATION GAS VALVE

If the actual manifold pressure is different than the rated pressure use the *PRESSURE REGULATOR ADJUSTMENT* on the valve to correct the manifold pressure. It will be necessary to remove the *CAP SCREW* to access the *PRESSURE REGULATOR ADJUSTMENT* (see diagram at above).

Be sure to disconnect the manometer and reinstall the plug in the valve's *OUTLET PRESSURE TAP* after the competition of gas manifold pressure test.

Maintenance



The restraining device must always be connected when the appliance is in service. Disconnect for movement, such as servicing or cleaning. Reconnect the restraining device after appliance has been returned to its normal position.



Failure to comply with the maintenance below could result in a serious accident or equipment damage.



Failure to remove power from this unit before performing maintenance may cause severe electrical shock. This unit may have more than one disconnect switch.

Scheduled Maintenance

Use the following table to help manage scheduled maintenance activities.

Frequency	Performed By	Part	Activity
Daily	User	Entire Oven	Perform oven-cleaning procedure.
Daily	User	Drive Rotor Gears	Lubricate planetary gear teeth.
6 months	User	Fan Blade	Remove and replace.

Cleaning is not only necessary for sanitary reasons, but will increase sales appeal and maximize operating efficiency.



Failure to remove power from this unit may cause severe electrical shock. This unit may have more than one disconnect switch.



Always wear appropriate personal protection equipment (goggles, rubber glove & long sleeved garments) when cleaning the oven to guard against possible injury.

Using abrasive cleaners will damage the cabinet finish. Use only a mild soap and water solution or approved cleaner.

DO NOT USE OVEN CLEANER on this machine. Caustic cleaners will cause damage to the machine.

NEVER USE A WATER HOSE OR A STEAM CLEANER TO WASH THIS UNIT. Excess water can get into the interior of the cabinet and cause damage.

BKI Approved Cleaning Solutions

- ECOLAB Greasestrip Plus
- Proctor & Gamble DCT Oven Cleaner
- J. Wilson Marketing Combi Brite Cleaner

Daily Cleaning & Maintenance

1. Allow oven to cool below **50° C-55° C (120° F-130° F)**.
2. Turn the Main Power Switch off and unplug the appliance.
3. Empty the Dripping Drawer using the drain valve or fat pump (refer to Figure 1 below).
4. Remove all food products from the unit.
5. Remove V-spits, or Baskets from the unit and place them in a large sink to soak in hot cleaning solution. Clean the components with warm water, a sponge and an approved cleaning solution. Wipe dry with a clean cloth.

6. Remove the Rotor System as described below:

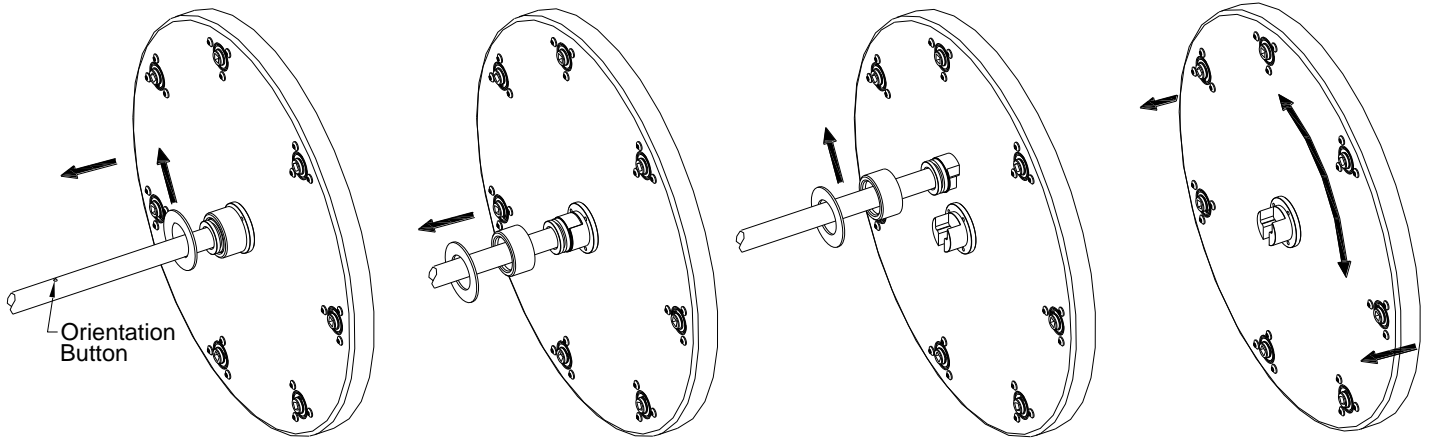

STEP 1

Rotate the rotor assembly until the orientation button in the center of the shaft is on top. Lift the Retaining Washers on each end of the shaft up & out of the grooves in the Hubs.

STEP 2

Slide the Retaining Cups off of the Hubs on each end of the shaft.

STEP 3

Lift the Rotor Shaft assembly out of the Hubs on the Rotors.

STEP 4

Remove the Rotor Disks from the oven by pulling out on the outside of the disks while rotating them back and forth.

- 7. Place the Rotor System components in a large sink to soak in hot cleaning solution. Clean the components with warm water, a sponge and an approved cleaning solution. Wipe dry with a clean cloth.
- 8. Remove the Fan Guard by pulling it straight out of the top of the oven cavity (refer to Figure 1 below).

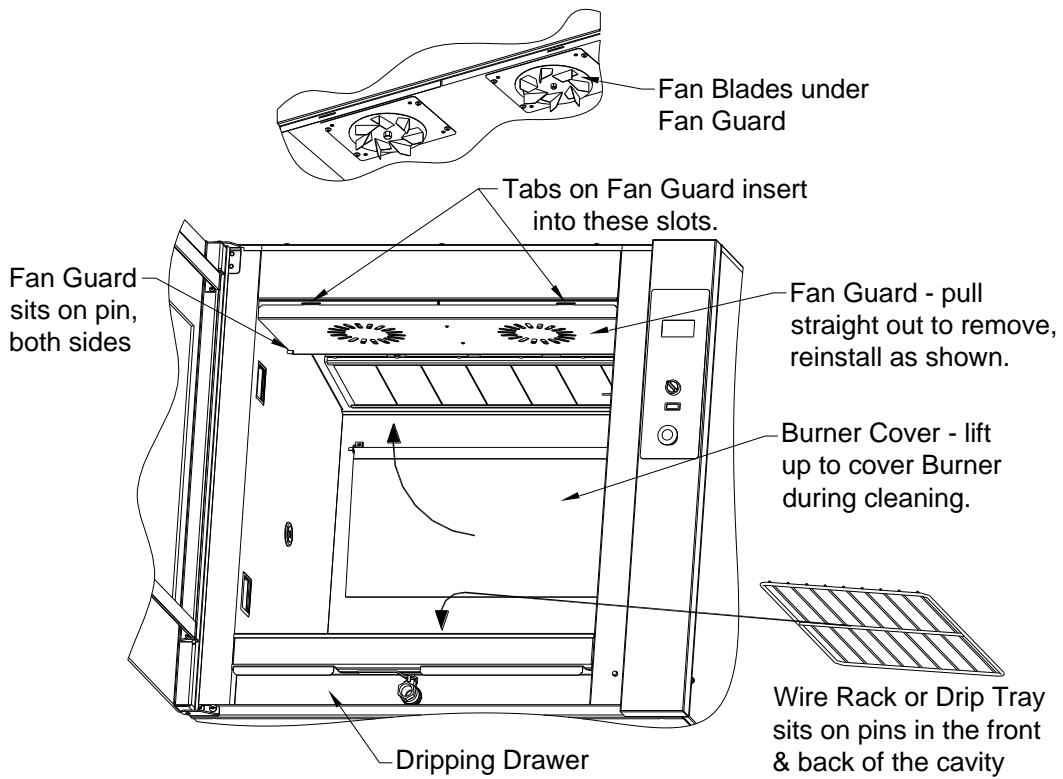
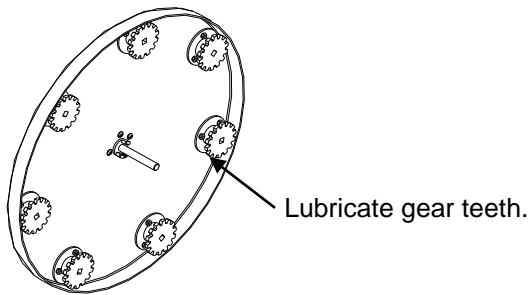

Figure 1

9. Remove the Wire Racks or Drip Tray and the Dripping Drawer from the oven (refer to Figure 1 above).

- 10. Clean the Fan Guard, Wire Racks or Drip Tray and Dripping Drawer with mild soap and water solution or approved cleaning solution and a sponge. Wipe dry with a clean cloth.
- 11. Clean in interior oven cavity with mild soap and water solution or approved cleaning solution and a sponge. Wipe dry with a clean cloth.
- 12. Carefully clean the fan blades using a mild soap and water solution or approved cleaning solution and a scrub brush. Do not bend or disfigure the fan blades.
- 13. Clean the outside of the oven with mild soap and water solution or approved cleaning solution and a sponge. Wipe dry with a clean cloth.
- 14. Replace the Fan Guard, Wire Racks or Drip Tray and Dripping Drawer in the oven cavity (refer to Figure 1 above).
- 15. Lubricate the gears on the Drive Rotor as shown below with Permatex® Super Lube® Synthetic Lubricant with PTFE (BKI part number L0200).



- 16. Reinstall Rotor System as shown below.

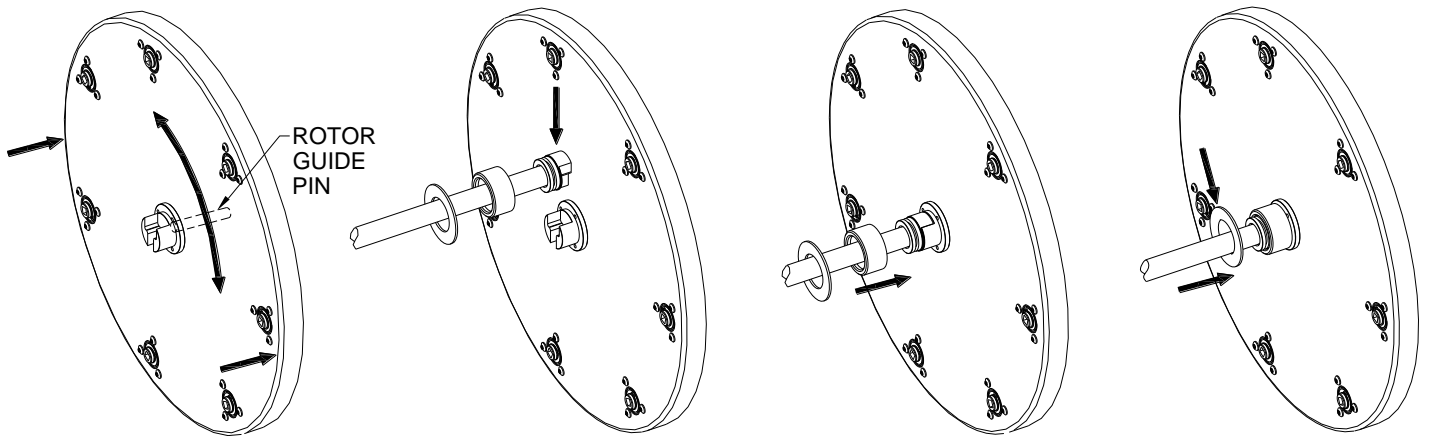

STEP 1
Install the Rotor Disks by first inserting the guide pin into the shaft center hole. The Rotor Disk with gears goes on the control side of the oven. It will be necessary to rotate this Rotor Disk while pushing in to engage the gears and the drive hub. When properly installed there will be approximately 1/4" [6 mm] space between the Rotor Disk and cavity side.

STEP 2
Rotate both Rotor Disks so that the wide side of the T-slot in the hubs is facing up as shown. Hold the Rotor Shaft with wide side of the T-shaped tabs in end hubs facing up. Slide the T-shaped tabs in the Rotor Shaft ends into the corresponding slots in the hubs.

STEP 3
Slide the Retaining Cups on each end of the Rotor Shaft completely onto the Rotor Hubs. The grooves in the Rotor Shaft end hubs must be visible.

STEP 4
Slide the Retaining Washers onto the Rotor Hubs and seat them in the grooves in the Rotor Shaft end hubs.

Troubleshooting

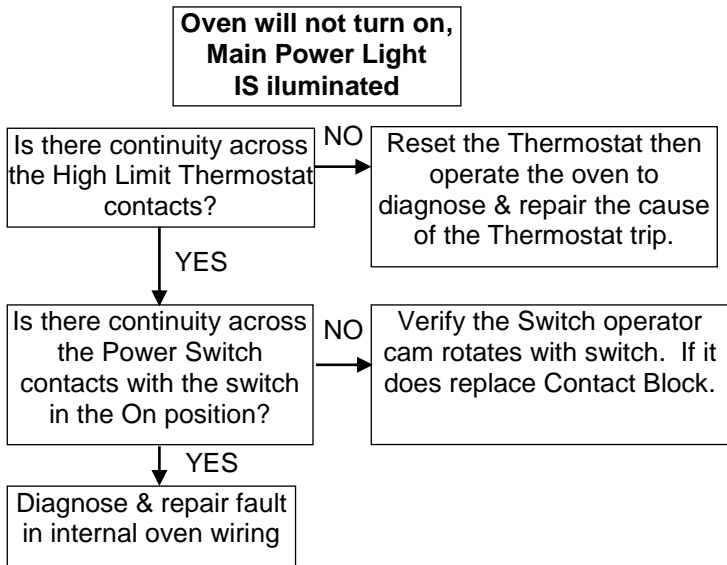
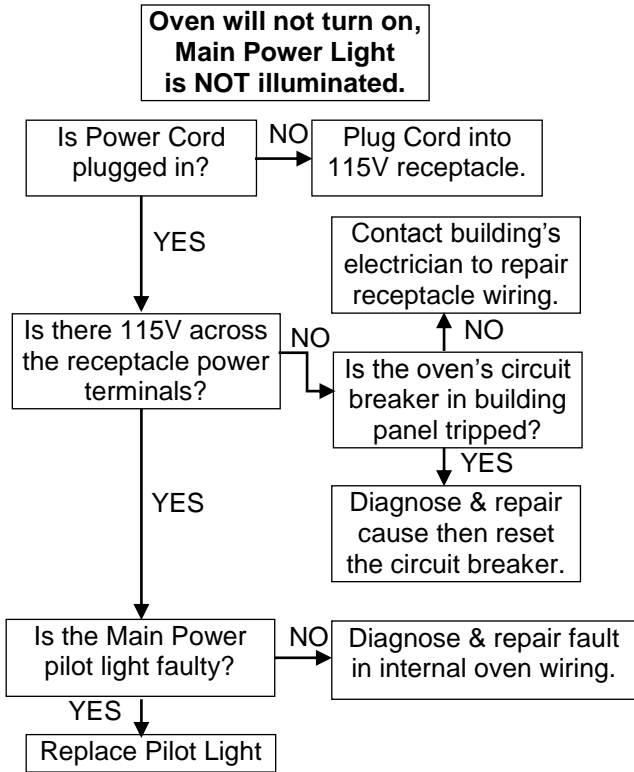

Rotors will not rotate with Door closed but will rotate when Jog Switch is pushed.

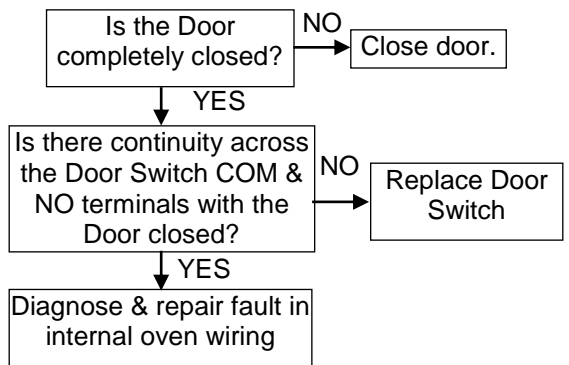

Rotors will not rotate with Door closed OR when the Jog Switch is pushed.

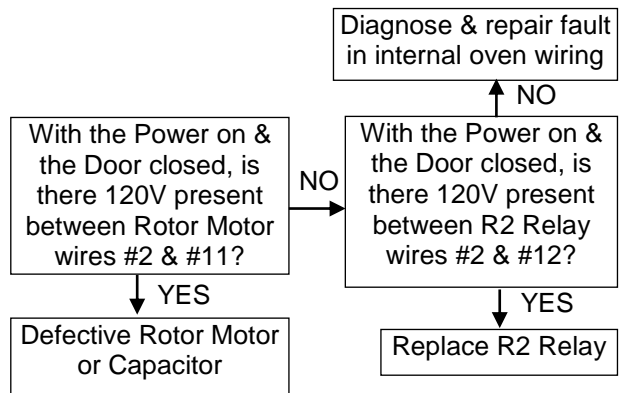

Rotors rotate with Door closed but will not rotate when Jog Switch is pushed.

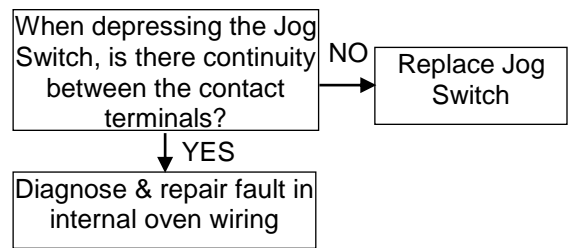

Rotors rotate but have a jerky motion.

Adjust rotor drive chain tension and alignment.

Oven Burner Will Not Light

The oven will try to ignite the burner for 6 seconds. If it fails to ignite the Spark / Ignition Control will lockout. The Power Switch will have to be cycled off & back on to reset the Spark / Ignition Control.

Turn oven Power Switch off and then back on. Make certain the Door is closed & start Controller and initiate a Preheat or Cook program.

With the Door closed, watch the Spark / Flame Sense Probe and Burner as the Controller calls for heat. Troubleshoot the problem as described below based on your observations.

ALL measurements described below are made with the Door closed & when the Controller is calling for heat.

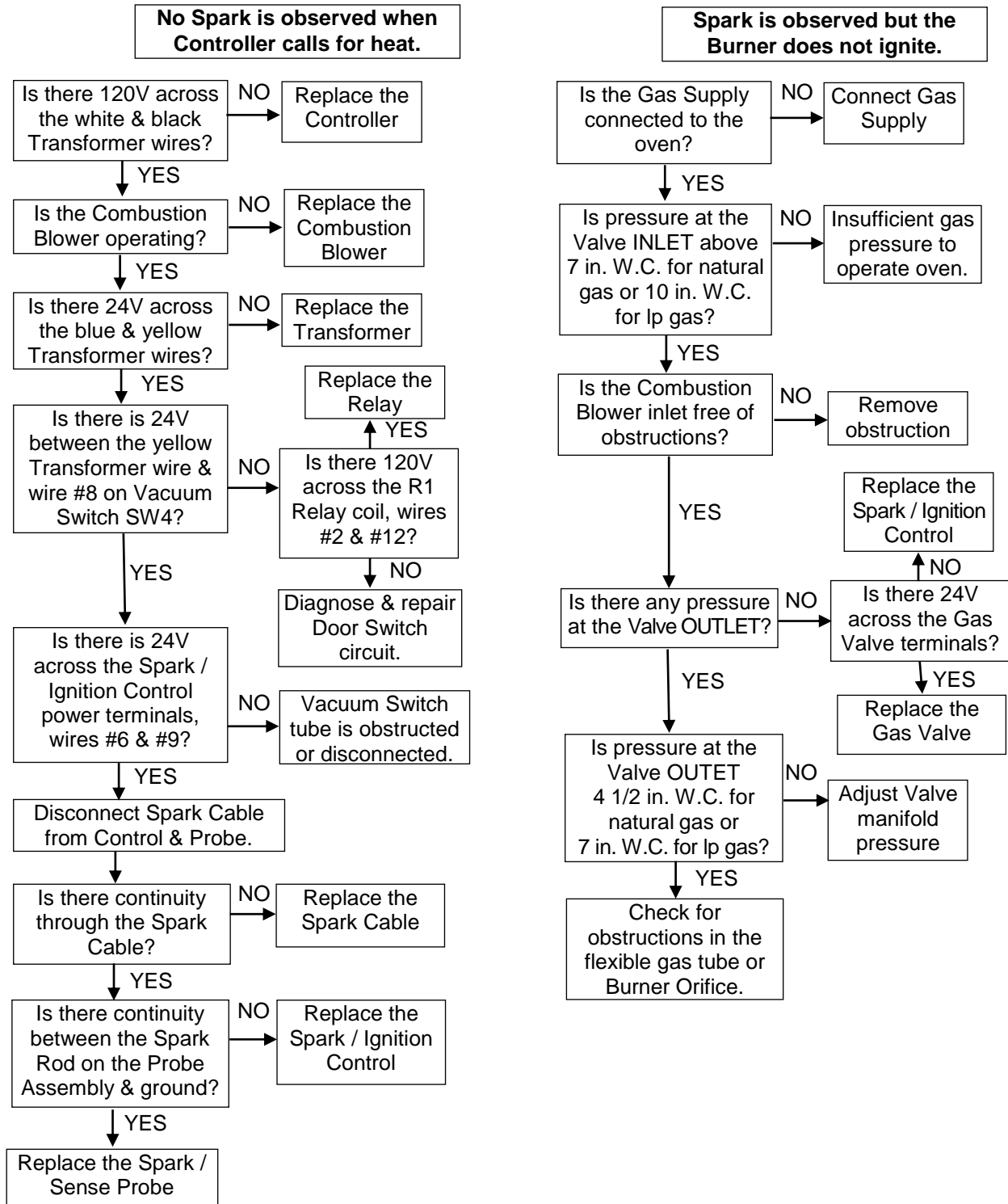

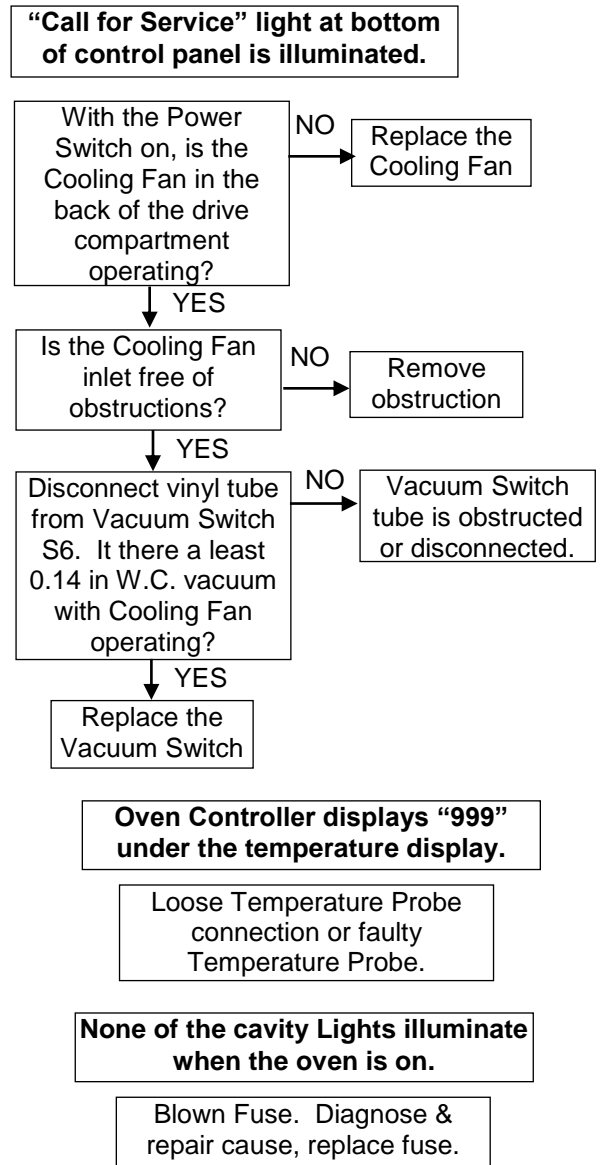
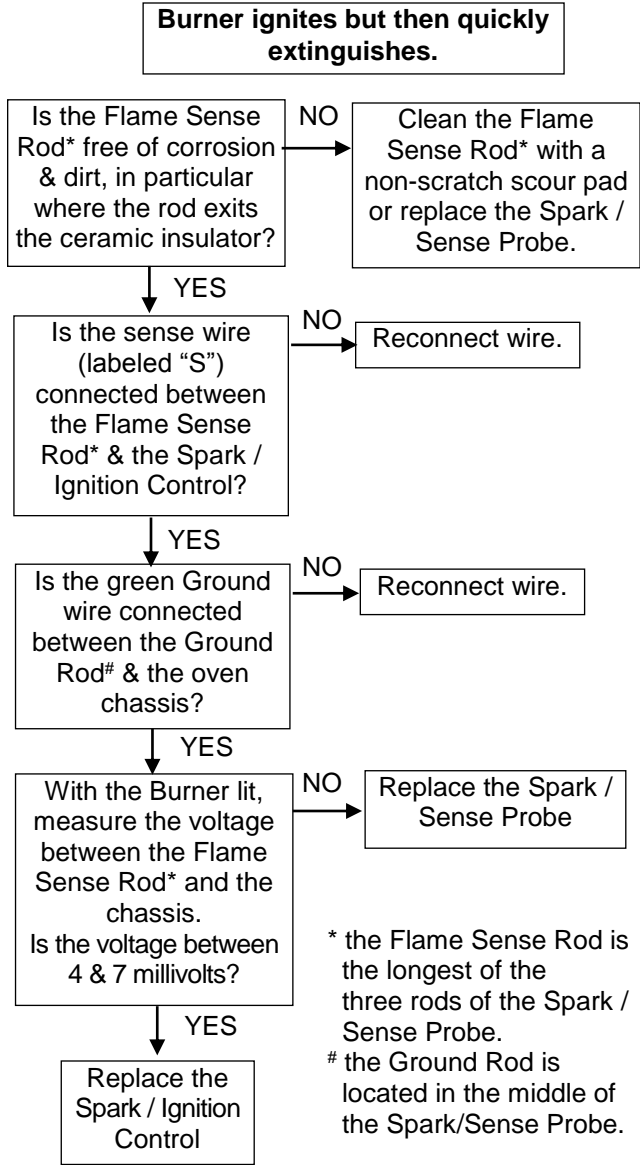

Accessories



G0089 HI-TEMP GLOVES



L0200 PTFE LUBRICANT

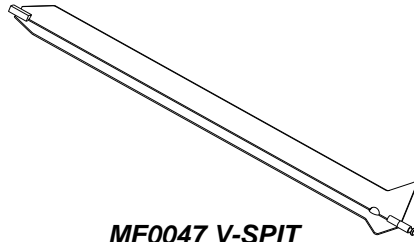

MF0047 V-SPIT

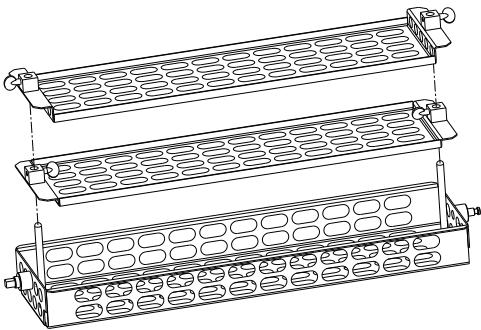

AB55310000 TIERED BASKET

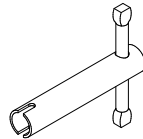

FA55313800 THUMB SCREW WRENCH

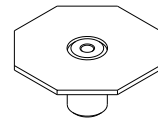

WA55314200 SPIT HOLDER
requires Ø1 1/2" mounting hole.

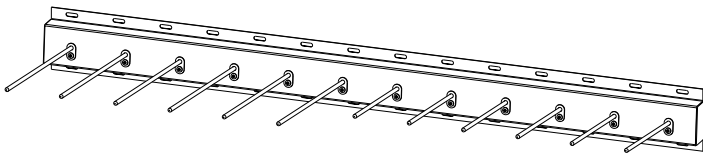

AB55315500 12 ROD SPIT RACK
(capacity- 60 V-Spits & 9 Baskets)

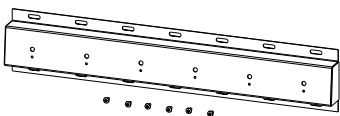

AB55317400 6 ROD RACK CHANNEL
(order Rods separately)

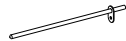

WA55315300 V-Spit Rod

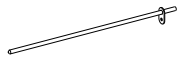

WA55315400 Basket Rod

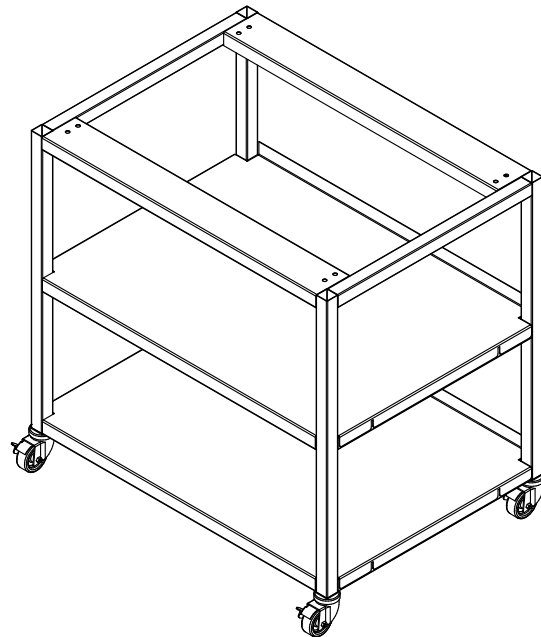

DRGV-7 STANDS

- AN55310700 Open Stand, Adjustable Feet
- AN55310800 2 Shelf Stand, Adjustable Feet
- AN55316200 Open Stand, Swivel Casters
- AN55316300 2 Shelf Stand, Swivel Casters (2 Shelf Stand with Swivel Casters shown.)

Replacement Parts

Use the information in this section to identify replacement parts. To order replacement parts contact your local BKI sales and service representative. Reference the oven serial number located on the rating tag when ordering replacement parts.

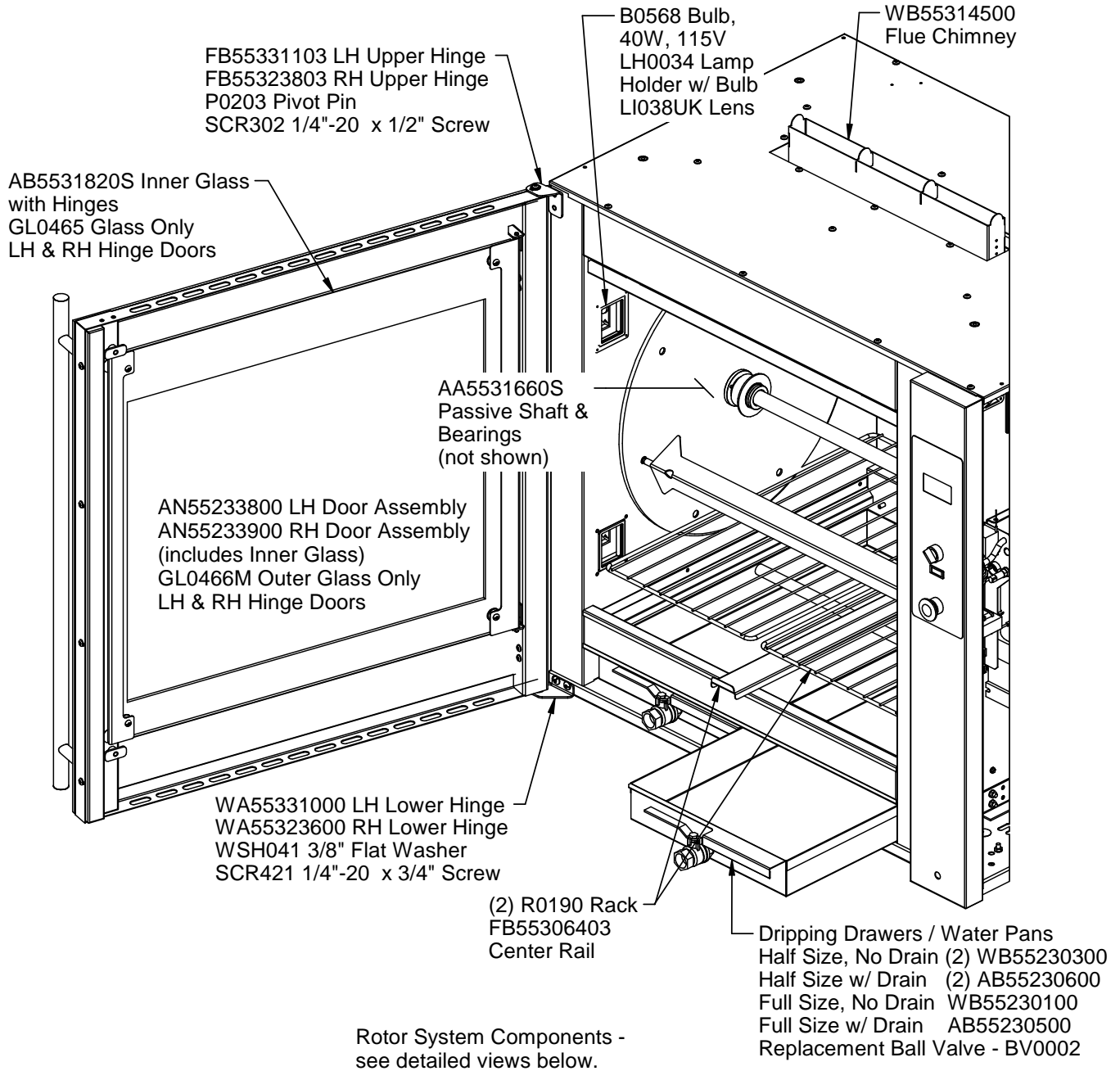

Cavity and Door Components

Complete Fan Assemblies
 FN0055 - CCW Rotation
 FN0056 - CW Rotation
 Assemblies include Fan
 Motor, Blade, Shim & Nut

Fan Motor
 FN0047 - CCW
 FN0050 - CW

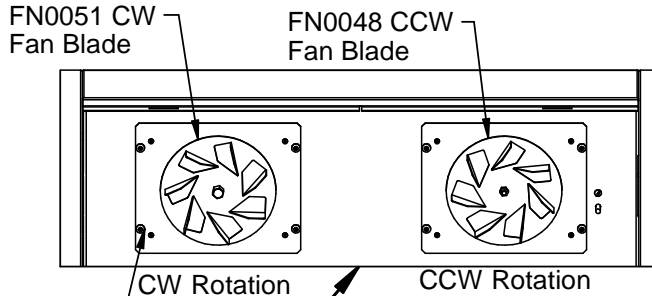
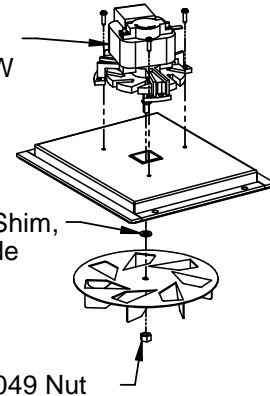

FN0053 Shim,
 Fan BLade

FN0049 Nut
 M6 LH Thread

Circulation Fan Assembly

Remove (4)
 screws, Fan
 assembly will
 drop down for
 service.

GB0015 Ceramic
 Infra-Red Burner
 GB0016-24 Orifice,
 Natural Gas
 GB0016-36 Orifice,
 LP Gas

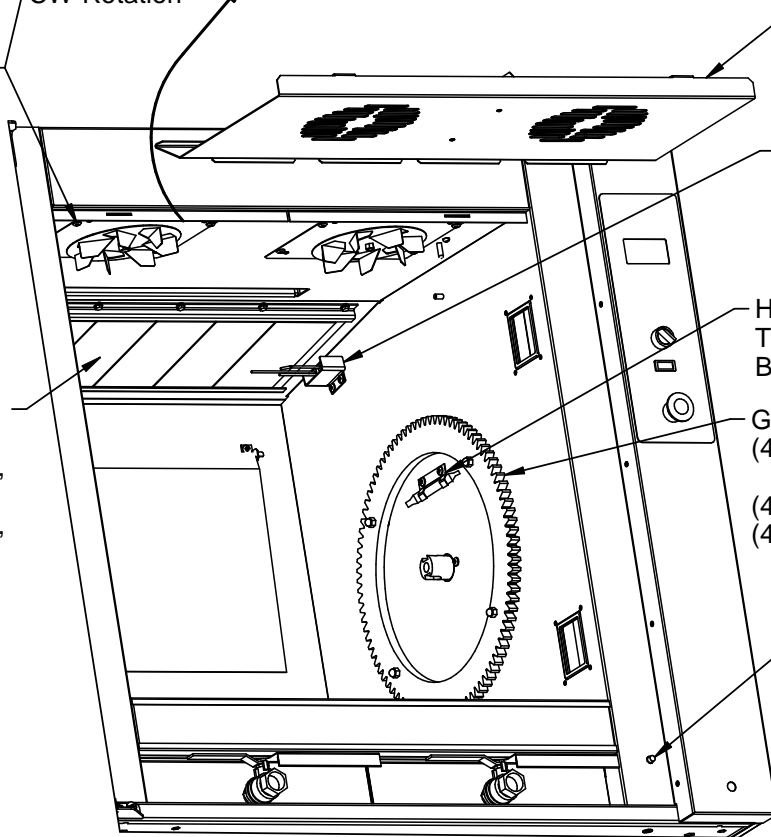

AB5531950S
 Circulation Bottom
 w/ Center Baffle

C0770
 Spark / Sense
 Probe
 FB55316803
 Probe Shield

High Limit
 Thermostat
 Bulb

G0138 Sun Gear
 (4) SCR493 Studs,
 1/4"-20 X 2"
 (4) SP0054 1/4" Spacers
 (4) NUT097 1/4"-20
 Cap Nuts

S0366
 Plunger
 Switch

Circulation Fans, Burner & Sun Gear

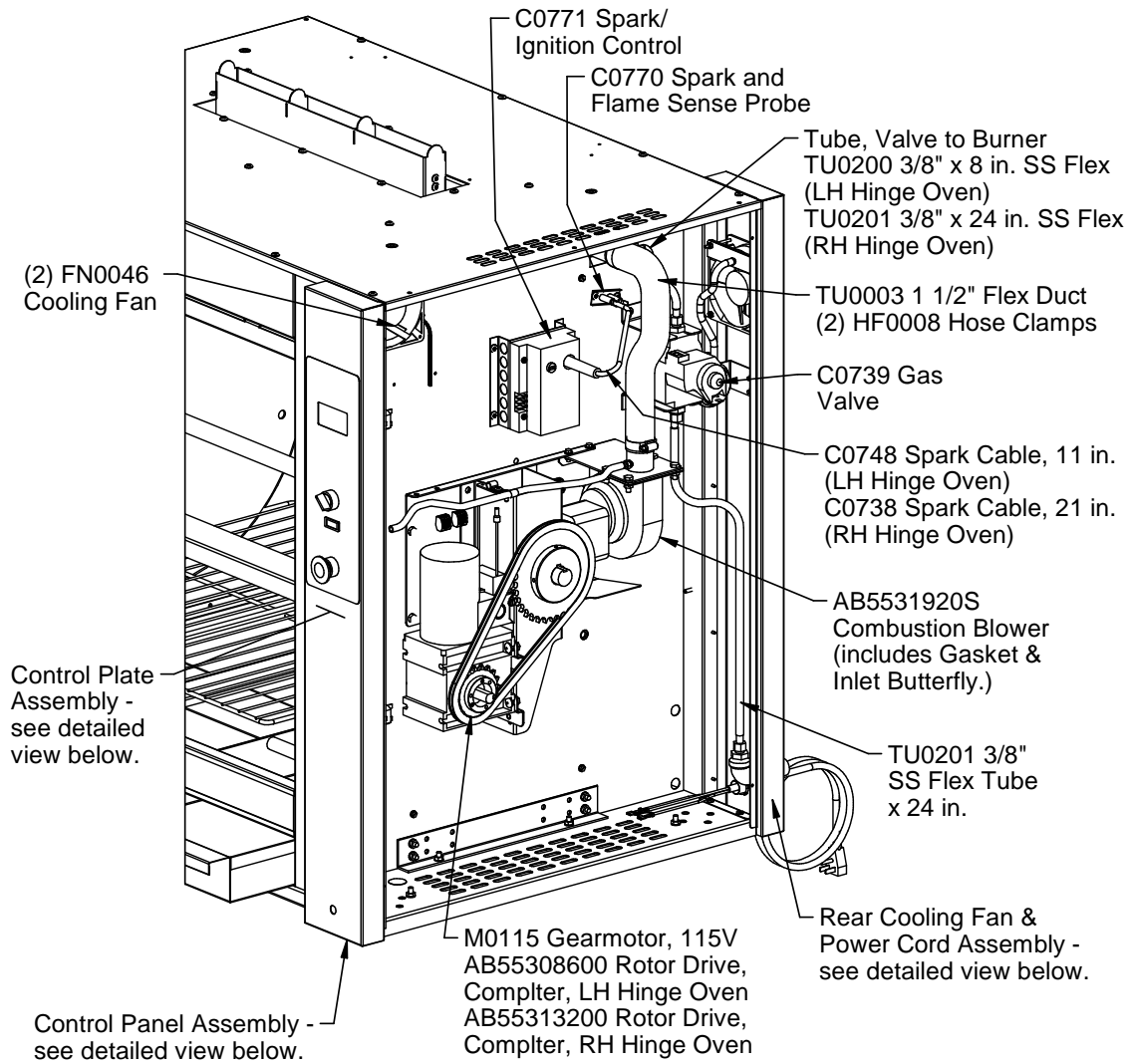

Drive Side Components

Complete Stacking Kits
 AB55332200 LH Hinge Oven
 AB55332700 RH Hinge Oven
 (assembly instructions in Installation section of this manual)

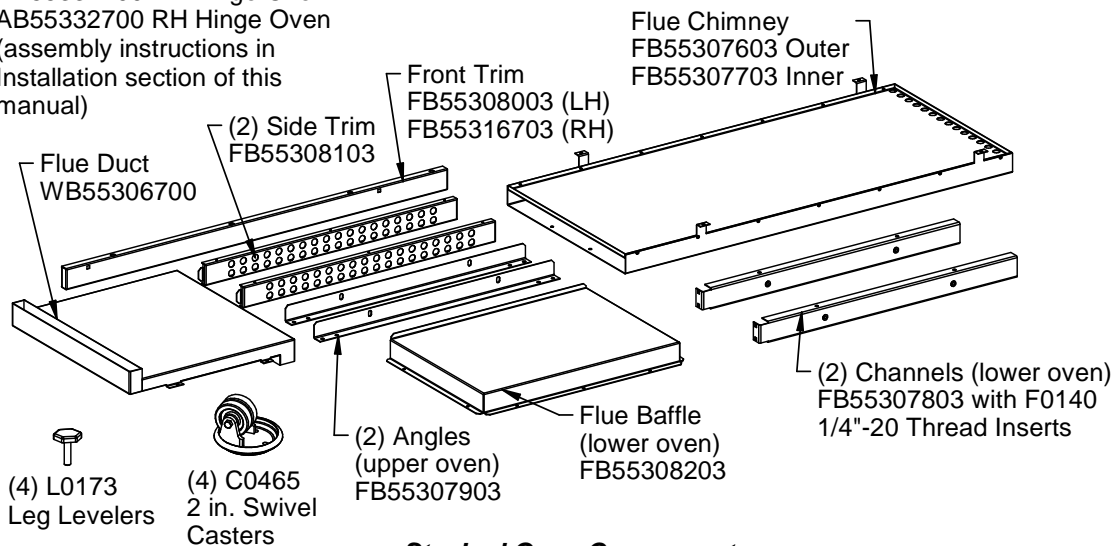

Stacked Oven Components

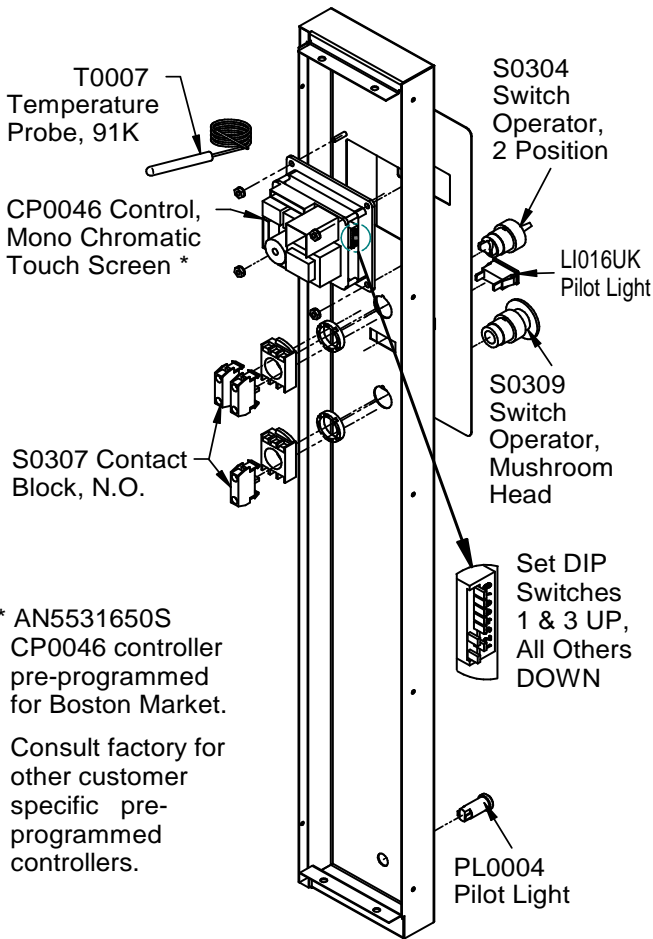

* AN5531650S
CP0046 controller
pre-programmed
for Boston Market.

Consult factory for
other customer
specific pre-
programmed
controllers.

Control Panel Components
(CP0046 mono-chrome control)

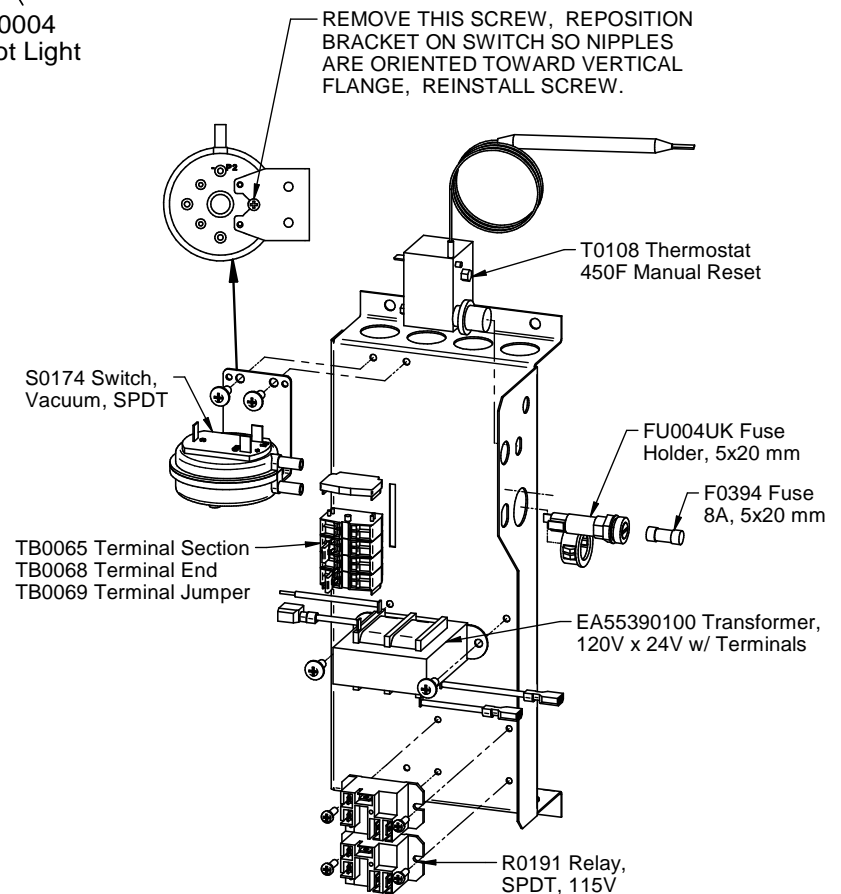

Control Plate Components

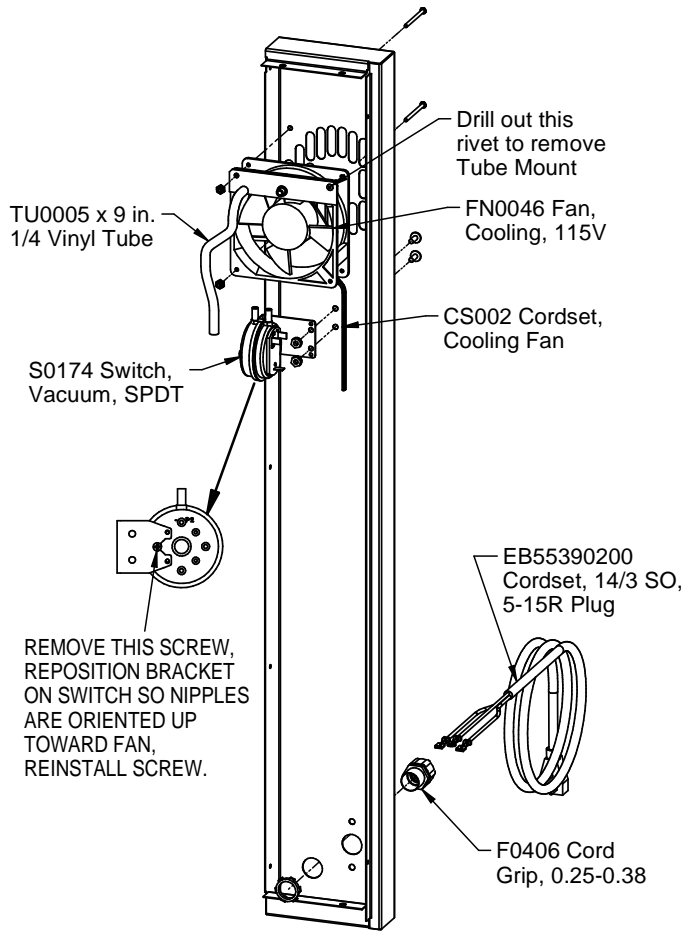

Rear Cooling Fan & Cord Components

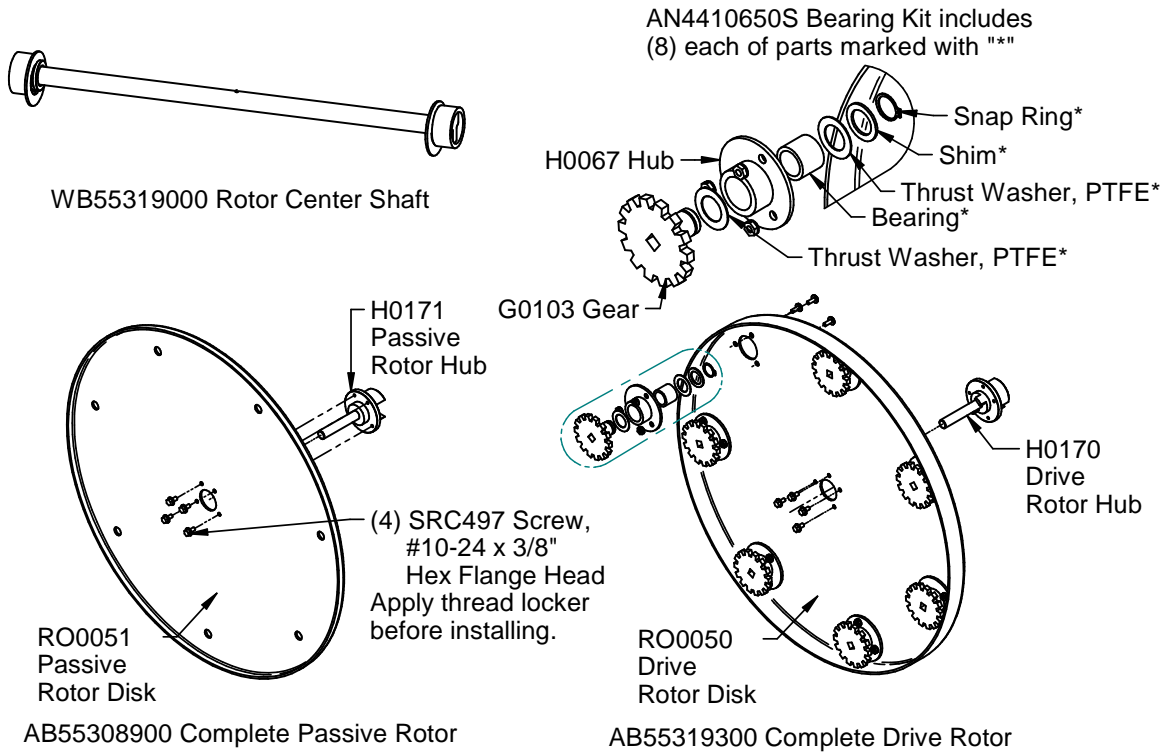

Rotor System Components

Wiring Diagram

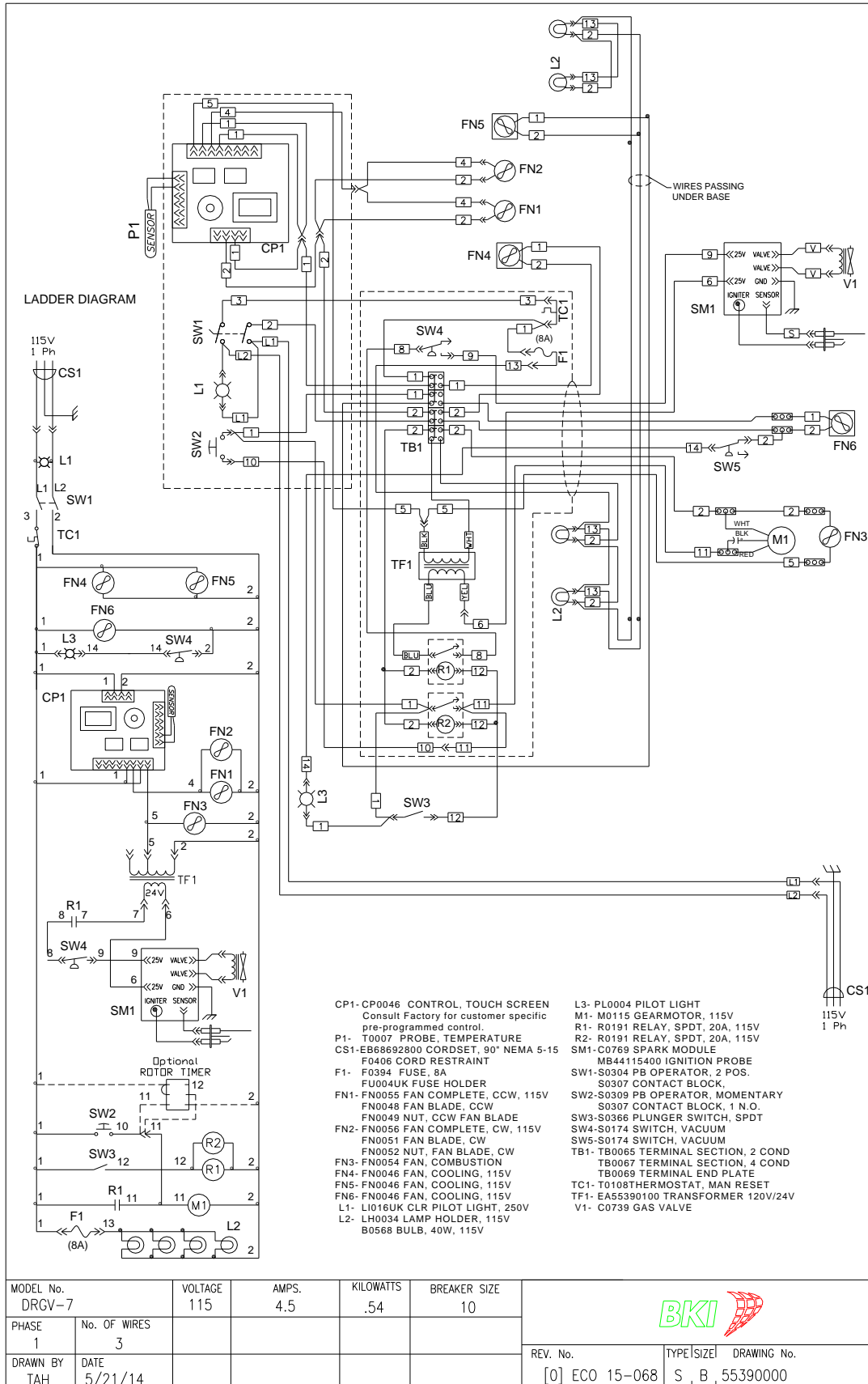

Notes



2812 Grandview Drive, Simpsonville, S.C. 29680, USA
<http://www.bkideas.com>

Made and printed in the USA

CS-TM-051.04

09/25/18